

NX-320E Remote Power Supply  
**Installation Manual**



**Copyright** Copyright © 2008 GE Security. All rights reserved.

This document may not be copied in whole or in part or otherwise reproduced without prior written consent from GE Security except where specifically permitted under US and international copyright law.

Document number/revision: **466-2299A** (April 2008).

**Disclaimer** The information in this document is subject to change without notice. GE Security ("GE") assumes no responsibility for inaccuracies or omissions and specifically disclaims any liabilities, losses, or risks, personal or otherwise, incurred as a consequence, directly or indirectly, of the use or application of any of the contents of this document. For the latest documentation, contact your local supplier or visit us online at [www.gesecurity.com](http://www.gesecurity.com).

This publication may contain examples of screen captures and reports used in daily operations. Examples may include fictitious names of individuals and companies. Any similarity to names and addresses of actual businesses or persons is entirely coincidental.

**Trademarks and patents** GE and the GE monogram are registered trademarks of General Electric Company.

Other trade names used in this document may be trademarks or registered trademarks of the manufacturers or vendors of the respective products.

**Intended use** Use this product only for the purpose it was designed for; refer to the data sheet and user documentation. For the latest product information, contact your local supplier or visit us online at [www.gesecurity.com](http://www.gesecurity.com).

**FCC compliance** This equipment has been tested and found to comply with the limits for a Class B digital device, pursuant to part 15 of the FCC rules. These limits are designed to provide reasonable protection against harmful interference when the equipment is operated in a residential environment. This equipment generates, uses, and can radiate radio frequency energy and, if not installed and used in accordance with the instruction manual, may cause harmful interference to radio communications.

Changes or modifications not expressly approved by the party responsible for compliance could void the user's authority to operate the equipment.

**EMC directive** The European Union directive on electromagnetic compatibility (2004/108/EC) requires non-European manufacturers to designate an authorized representative in the Community. Our European representative is GE Security, Kelvinstraat 7, 6003 DH Weert, Nederland.



The European directive *Waste Electrical and Electronic Equipment* (WEEE) aims to minimize the impact of electrical and electronic equipment waste on the environment and human health. For proper treatment, recovery, and recycling, return the equipment marked with this symbol to your local supplier upon the purchase of equivalent new equipment, or dispose of it in designated collection points. For more information, visit [www.recyclethis.com](http://www.recyclethis.com).

**Regulatory** 

# Contents

<b>Preface</b> .....	<b>1</b>
Conventions used in this document .....	1
Safety terms and symbols .....	1
<b>Product overview</b> .....	<b>2</b>
Product contents .....	2
UL requirements .....	2
<b>Installation</b> .....	<b>3</b>
Wiring .....	4
Battery .....	6
Addressing .....	7
LEDs .....	8
Enrolling .....	8
<b>Programming</b> .....	<b>9</b>
Programming data .....	10
Using an LCD keypad .....	10
Programming locations .....	11
<b>Programming worksheets</b> .....	<b>15</b>
<b>Specifications</b> .....	<b>19</b>
<b>Contacting us</b> .....	<b>20</b>
Online resources .....	20



## Preface

This is the *GE NX-320E Remote Power Supply Installation Manual*, which describes the following:

- how to install the power supply; and
- how to program the power supply.

There is also information describing how to contact technical support if you have questions or concerns. To use this document effectively, you should have the following minimum qualifications:

- a basic knowledge of NetworX Series products; and
- a basic knowledge of power supplies.

Read these instructions and all ancillary documentation entirely **before** installing or operating this product. The most current versions of this and related documentation may be found on our website. Refer to [Online resources](#) on page 20 for instructions on accessing our online publication library.

**Note:** A qualified service person, complying with all applicable codes, should perform all required hardware installation.

## Conventions used in this document

The following conventions are used in this document:

<b>Bold</b>	Menu items and buttons.
<i>Italic</i>	Emphasis of an instruction or point; special terms.
	File names, path names, windows, panes, tabs, fields, variables, and other GUI elements.
	Titles of books and various documents.
<i>Blue italic</i>	(Electronic version.) Hyperlinks to cross-references, related topics, and URL addresses.
Monospace	Text that displays on the computer screen.
	Programming or coding sequences.

## Safety terms and symbols

These terms may appear in this manual:



**CAUTION:** *Cautions* identify conditions or practices that may result in damage to the equipment or other property.



**WARNING:** *Warnings* identify conditions or practices that could result in equipment damage or serious personal injury.

## Product overview

The NX-320E is a microprocessor-controlled remote power supply module for the NetworX control panels. The module has three programmable outputs (A, B, C) and one programmable style Y bell output. You can add up to eight power supply modules for a total of 32 outputs. You can use the A, B, and C programmable outputs as auxiliary power, for smoke detectors and sirens. (See *Specifications* on page 19.) Each power supply module has a tamper terminal that can be used to supervise the metal enclosure. Do not use more than 2500 ft. of wire from the NX-320E to all outgoing devices.

## Product contents

The NX-320E Remote Power Supply includes the following:

- Board
- Board guides
- Transformer
- Diodes (2), black wrap is for fire installation
- Resistors (2), white wrap for fire installation

You will also need the following items that are not included with the NX-320E:

- 22 gauge 4-conductor wire (*Table 1* on page 4)
- Battery (*Table 3* on page 6)

## UL requirements

The NX-320E meets the Underwriters Laboratories (UL) standards, including the following:

- UL365 Police Station Connected Burglar Alarm Units and Systems
- UL609 Local Burglar Alarm Units and Systems
- UL864 Control Units for Fire-protective Signaling Systems
- UL985 Household Fire Warning Systems
- UL1023 Household Burglar Alarm Systems
- UL1610 Central Station Burglar Alarm Units

When the NX-320E is part of a UL commercial fire security system, this unit is compatible with the following:

- NX-148E-CF LCD keypad
- NX-216E zone expander
- NX-507E relay expander
- 13-474 horn/strobe 15-75 CD (for proper strobe operation, change Location 6, Segment 1 from 16 to 13)

For UL installations, the Class II, Class III, and power-limited fire alarm circuits must be installed using FPL, FPLP, FPLR, CLIII, CLIIIR, or CLIIIP, or substitute cable permitted by National Electrical Code ANSI/NFPA70. If you have Class II, Class III, and power-limited fire alarm circuit conductors that extend beyond the cable jacket, separate the wires by a 0.25 in. from all other conductors or use nonconducting tubing.

## Installation

There are several two-holed insertion points inside the enclosure so you can install the module either horizontally or vertically. The insertion points have a large hole and a smaller hole.

To mount the board in an enclosure, see *Figure 1* and do the following:

1. Place a black plastic PCB guide in the top insertion point, grooved edge downward. The half-moon protrusion will be in the large hole. Do not use excessive force.
2. Insert one of the included screws into the smaller hole (from the inside of the can) to secure it in place. A screwdriver should reach through the notch that runs the length of the guide to tighten the screw.
3. Position the other PCB guide opposite the first (grooved edge up) and placed in the lower insertion point, using the same procedure. Once you mount the guide, screw it in securely.
4. Slide the board into the grooves of both guides. The PC board should slide freely.

Figure 1. Board installation

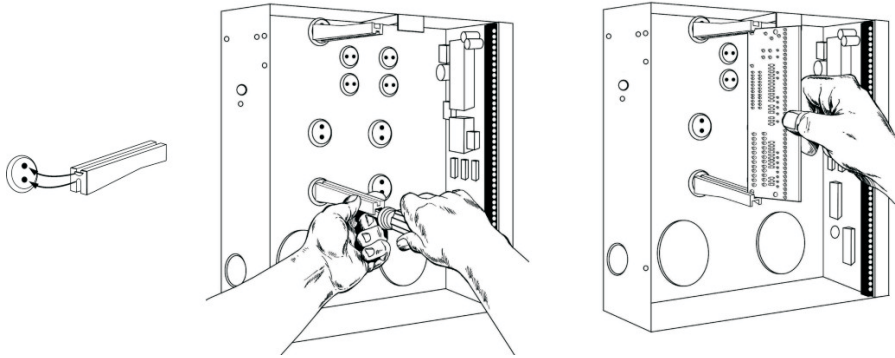

## Wiring

When you connect the unit, do the following:

- For UL commercial fire installations, use at least 18 AWG for all field wiring. We do not recommend shielded wire.
- Use a 16.5 VAC 50 VA / 120 V, 60 Hz hard-wired transformer (GE Security #T-0002).

Do not connect multiple power supply modules in a series (cascaded). The board is wrapped in bubble wrap. Unwrap it so you can orient yourself as you review *Figure 2*.

Figure 2. Board connections

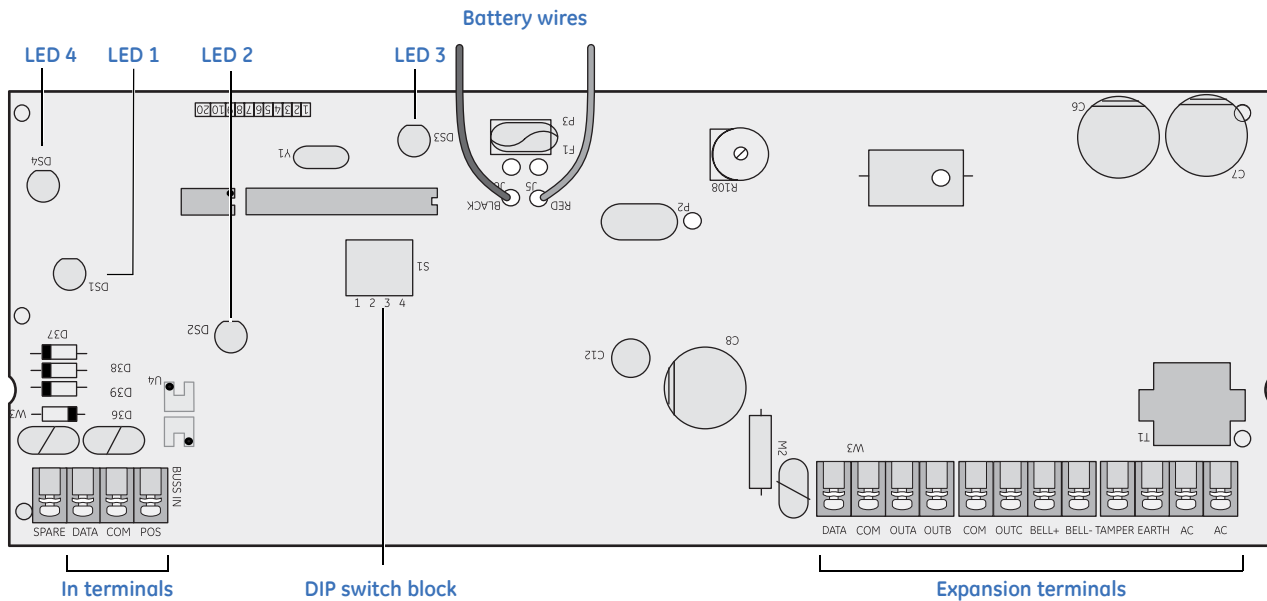

## Wiring requirements

Use *Table 1* to calculate your wiring requirements. We do not recommend shielded wire. For UL Commercial Fire installations, a minimum of 18 AWG must be used for all field-wiring applications.

Table 1. Wiring requirements

Length (in ft.)	Wire gauge (when connected to Network panel)
400	24
500	24
1000	24
2000	22
2500	20



## Connections

Connect the terminals described in *Table 2*. The total wire run from the control panel to all devices, including the NX-320E is 2500 feet.

Table 2. Terminal descriptions

Terminal	Description
<b>Control panel terminals</b>	
DATA	Connect to the control panel's <i>Data</i> terminal. This terminal is the incoming data-signaling terminal to the NX-320E module.
COM	Connect to the control panel's <i>Common</i> terminal. This terminal supplies the common side of the power to the NX-320E module.
POS	Connect to the control panel's <i>Aux power +</i> terminal. This terminal supplies power to the NX-320E module.
<b>Accessory terminals</b>	
DATA	Connect the <i>outgoing</i> data-signaling terminal for bus extension.
COM	Common terminal for any device powered from the NX-320E.
Out A and B <sup>a</sup>	Connect programmable output current limited to 1.5 A.
COM <sup>a</sup>	Connect any device powered from the NX-320E.
OUT C <sup>a</sup>	Connect programmable output current limited to 1.5 A.
BELL+ and BELL-	Connect bell as in <i>Figure 3</i> on page 6. The current is limited to 2.5 A.
TAM	Connect an optional <i>Tamper</i> terminal. To use this feature, connect the normally closed tamper switch between this terminal and <i>COM</i> . If DIP switch 4 is off, this feature is not used.
EARTH	Connect earth ground.
AC	Connect AC input. Connect to a 16.5 V 50 VA Class II UL approved transformer.

a. The total current on the NX-320E should not exceed 2.0 A.

## Bell output connections

The bell output (*Figure 3*) is voltage only and is pulsed (temporal) during a fire alarm and steady during a burglar alarm. GE includes the diode (#EOL-D5400) and resistor (#EOL-33) necessary to complete the installation. If the audible device is commercial fire listed, you do not need the diode (#EOL-D5400). Remember to use the black-wrapped diode and white-wrapped resistor for fire installations. The bell circuit current is rated at 2.5 A maximum.

Figure 3. Bell output wiring

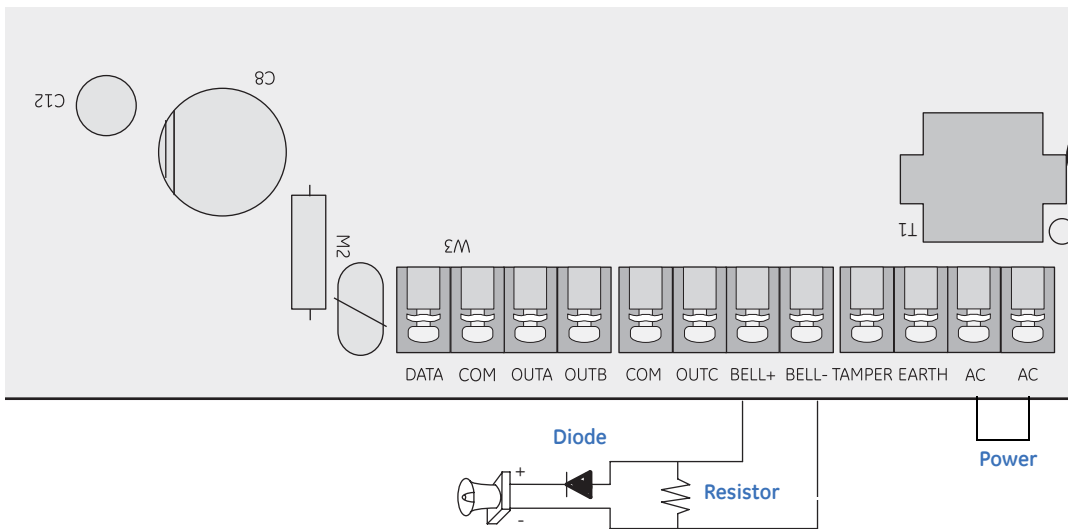

## Battery

The battery is not included with the NX-320E. You need the battery for emergency backup. We recommend the Yuasa NP18-12B battery (12 V, 17 Ah). The battery capacity for emergency standby should be at least 24 hours. UL installations must use at least one 17.2 Ah battery for 24 hours of backup. The control panel draws 50 mA standby power.

Use *Table 3* to calculate your battery requirements..

Table 3. Battery calculation table

Standby time	Total auxiliary current	Standby battery capacity	Alarm current
24 hours	1.9 A	51 Ah	600 mA
	1.25 A	34 Ah	1 A
	600 mA	17 Ah	1 A
48 hours	900 mA	51 Ah	1 A
	600 mA	34 Ah	1 A
	300 mA	17 Ah	1 A
72 hours	600 mA	51 Ah	1 A
	400 mA	34 Ah	1 A
	200 mA	17 Ah	1 A

To install the battery, connect the red and black wires to your battery (Figure 4).

Figure 4. Battery connection

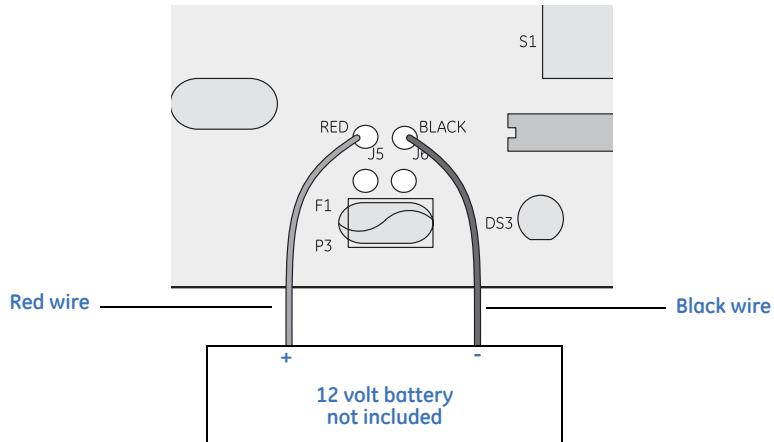

## Addressing

Use the DIP switches to set the module address (84 to 91). Table 4 shows the address settings. Use DIP switch 4 to set the tamper feature: *On* = enabled, *Off* = disabled.

Table 4. Addresses

Address	DIP switch 1	DIP switch 2	DIP switch 3
84	Off	Off	Off
85	On	Off	Off
86	Off	On	Off
87	On	On	Off
88	Off	Off	On
89	On	Off	On
90	Off	On	On
91	On	On	On

## LEDs

The power supply module has four red LEDs to provide status information. See *Figure 2* and *Table 5* for locations and descriptions of the LEDs.

Table 5. LED connections

LED	Board ID	Description
LED 1	DS1	Flashes when data is transmitted from the NX-320E.
LED 2	DS2	Flashes when data is transmitted into the NX-320E.
LED 3	DS3	Flashes during normal operation.
LED 4	DS4	Glow dimly when connected to the NetworX panel. (See <a href="#">Specifications</a> on page 19).

## Enrolling

The NetworX control panel can locate and store the presence of keypads, zone expanders, and wireless receivers, and other modules connected to the data terminal. This allows these modules to be supervised by the control panel. To enroll the modules, enter NetworX control panel program mode and then exit program mode. The panel automatically enrolls the devices. The process takes about 12 seconds. During this time, the Service LED illuminates and you cannot enter user codes. If you enroll a module that the system cannot detect, the Service LED will illuminate.

## Programming

You can use an LED keypad or LCD keypad to program the module.

### Using an LED keypad

To program the module with an LED keypad, do the following:

1. Enter \*, **8**. All of the function key LEDs will begin to flash.
2. Enter the *Go To Program* code (default is **9713**). If the code is valid, the Service LED will flash, and the function LEDs will illuminate steadily, indicating you should enter the device to program.
3. To enter a module address, press **8, 6, #** (See *Table 4* on page 7). The Armed LED will illuminate while it is waiting for a programming location to be entered.
4. Enter the programming location followed by the # key. The Armed LED will begin to flash. If this is a valid location, the Armed LED will extinguish, the Ready LED will illuminate, and the binary data for the first segment of this location will appear on the Zone LED.
5. To change the data, enter the data followed by the \* key. The location will automatically increment to the next segment. The data for that segment will display. Repeat the procedure until the system reaches the last segment.
6. To exit this location without changing the data, press the # key.
7. To review the data, press the \* key but do not enter the data. Each time you press \*, the next segment displays. After you program the last segment for a location, press \* to exit that location. The system will turn the Ready LED off and the Armed LED on. As before, you are now ready to enter another programming location.

**Note:** If you attempt to program an invalid entry for a particular segment, the keypad sounder will emit a triple-beep and remain in that segment until there is a valid entry.

8. To enter another location, do one of the following:
  - Enter the location number followed by the # key.
  - Press **Police** for the next location.
  - Press **Fire** for the previous location.
  - Press **Auxiliary** for the same location.
9. Press **Exit** to exit this module. Press **Exit** again, to completely exit program mode.

## Programming data

When you program data, you set numerical data or feature selection data.

**Numerical data.** Use the numeric keys of the system keypad with a number from 0 to 255. The system uses a binary process, so to view the data, look at the LEDs for zones 1 through 8 and see which ones are illuminated. When you add the illuminated LEDs together, you get the programming location. The numeric equivalents of these LEDs include the following:

Zone 1 LED = 1

Zone 5 LED = 16

Zone 2 LED = 2

Zone 6 LED = 32

Zone 3 LED = 4

Zone 7 LED = 64

Zone 4 LED = 8

Zone 8 LED = 128

For example, if you want to program 66 in a location, press **6, 6** on the keypad. The LEDs for Zone 2 and Zone 7 will illuminate, which indicates 66 is in that location ( $2 + 64 = 66$ ). Once you program the data, press the \* key to enter the data and advance to the next segment for that location. After the last segment of a location is programmed, you can press the \* key to exit that location and turn the Ready LED off and the Armed LED on. You can now enter another programming location. If you attempt to program a number that is too large, the keypad sounder will emit a triple-beep and will await a valid entry.

**Feature selection data.** Feature selection data will display the current condition (on or off) related to the eight features associated with the programming location and segment you selected. Press a button on the touchpad (1 to 8) that corresponds to the *feature number* within a segment you require. That feature number will illuminate (feature on). Press the number again, and the LED will extinguish (feature off). You will see that you can select numerous features from within one segment. For instance, if you require all eight segments, press **1, 2, 3, 4, 5, 6, 7, 8**. LEDs 1 through 8 will illuminate as you press the keys, to indicate that those features are enabled.

## Using an LCD keypad

The steps to programming using an LCD keypad are identical to *Using an LED keypad* on page 9. The only difference is that the LCD keypad will prompt you for the data required. In programming mode, the number in parentheses is the location you previously changed. For example, if the display reads `Enter location,` then `# (2)`, the system is telling you that Location 2 was the last location you programmed. In feature selection data, the numbers of the enabled features are displayed. The features not enabled will include a hyphen (-).

## Programming locations

**Location 0 - event and time for output A.** This location has two segments of numerical data. To program the event and time set the following:

- **Segment 1.** Select the event that triggers Output A. See *Table 6* for events you can trigger.
- **Segment 2.** Select how long an output will remain activated when an output triggers. For a location that is programmed as zero, the output will follow the event.

Table 6. Event and time programming for Output A

#	Event	#	Event	#	Event
0	Always on	11	Smoke power reset	22	Disarmed
1	AC fail (control or exp.) <sup>a</sup>	12	Yelping siren	23	Ready to arm
2	Low battery (control or exp.)	13	Steady siren	24	Not ready to arm
3	Dynamic battery test time	14	Any siren	25	Fire
4	Listen in	15	Steady siren (temporal)	26	Fire trouble
5	Line seizure	16	Any siren (temporal)	27	Chime
6	Telephone line fault	17	Alarm memory	28	Beeping keypad
7	Program mode	18	Entry	29 <sup>b</sup>	Aux 1 keypad function
8	Overcurrent (control or exp.)	19	Exit	30 <sup>b</sup>	Aux 2 keypad function
9	Box tamper (control or exp.)	20	Entry or exit	31 <sup>b</sup>	Panic keypad function
10	Siren tamper (control or exp.)	21	Armed	32 <sup>b</sup>	Code entry (set in loc 8–17)

a. Does not follow AC fail delay time.

b. If set to the following condition, these events will be one second.

**Location 1 - special features for output A.** This location has two segments of feature selection data to program special features for output A (see *Table 7*).

Table 7. Special features for output

Number	Segment 1 output	Segment 2 event
1	On for minutes; Off if output times in seconds.	On to activate when it occurs in Partition 1.
2	On if latched until a code is entered; Off for timed.	On to activate when it occurs in Partition 2.
3	On to stop time when a code is entered.	On to activate when it occurs in Partition 3.
4	On for inverted output.	On to activate when it occurs in Partition 4.
5	On to disable during listen-in (only events 12 to 16).	On to activate when it occurs in Partition 5.
6	Reserved.	On to activate when it occurs in Partition 6.
7	Reserved.	On to activate when it occurs in Partition 7.
8	Reserved.	On to activate when it occurs in Partition 8.

**Location 2 - event and time for output B.** This location has two segments of numerical data to program the event and time for output B.

- **Segment 1.** Select the event that triggers output B (See *Table 6* on page 11).
- **Segment 2.** Select how long an output will remain activated when an output triggers. For a location that is programmed as zero, the output will follow the event.

**Location 3 - special features for output B.** This location has two segments of feature selection data to program special features for output B (see *Table 7*).

**Location 4 - event and time for output C.** This location has two segments of numerical data to program the event and time for output C.

- **Segment 1.** Select the event that triggers output C. (See *Table 6* on page 11).
- **Segment 2.** Select how long an output will remain activated when an output triggers. For a location that is programmed as zero, the output will follow the event.

**Location 5 - special features for output C.** This location has two segments of feature selection data to program special features for output C (see *Table 7*).

**Location 6 - event and time for the bell output.** This location has two segments of numerical data to program the event and time for the bell output.

- **Segment 1.** Select the event that triggers the bell output. (See *Table 6* on page 11).
- **Segment 2.** Select how long an output will remain activated when an output triggers. For a location that is programmed as zero, the output will follow the event.

**Location 7 - special features for the bell output.** This location has two segments of feature selection data to program special features for the bell output (see *Table 7*).



**Location 8 - codes 1 to 10, output enable.** This location has 10 segments of feature selection data. When you activate outputs with a user code (event #30), you can use Location 8 to restrict certain codes from activating certain outputs. Segment 1 corresponds to user 1; Segment 10 corresponds to user 10. The LEDs correspond to outputs A to C (see *Table 8*).

Table 8. Output enable

LED	Description
1	On if code will activate Output A; Off if it will not.
2	On if code will activate Output B; Off if it will not.
3	On if code will activate Output C; Off if it will not.
4	Reserved.

**Location 9 - codes 11 to 20, output enable.** This location has 10 segments of feature selection data. When you activate outputs with a user code (event #30), you can use Location 9 to restrict certain codes from activating certain outputs. Segment 1 corresponds to user 11; Segment 10 corresponds to user 20. The LEDs correspond to outputs A to C (see *Table 8*).

**Location 10 - codes 21 to 30, output enable.** This location has 10 segments of feature selection data. When you activate outputs with a user code (event #30), you can use Location 10 to restrict certain codes from activating certain outputs. Segment 1 corresponds to user 21; Segment 10 corresponds to user 30. The LEDs correspond to outputs A to C (see *Table 8*).

**Location 11 - codes 31 to 40, output enable.** This location has 10 segments of feature selection data. When you activate outputs with a user code (event #30), you can use Location 11 to restrict certain codes from activating certain outputs. Segment 1 corresponds to user 31; Segment 10 corresponds to user 40. The LEDs correspond to outputs A to C (see *Table 8*).

**Location 12 - codes 41 to 50, output enable.** This location has 10 segments of feature selection data. When you activate outputs with a user code (event #30), you can use Location 12 to restrict certain codes from activating certain outputs. Segment 1 corresponds to user 41; Segment 10 corresponds to user 50. The LEDs correspond to outputs A to C (see *Table 8*).

**Location 13 - codes 51 to 60, output enable.** This location has 10 segments of feature selection data. When you activate outputs with a user code (event #30), you can use Location 13 to restrict certain codes from activating certain outputs. Segment 1 corresponds to user 51; Segment 10 corresponds to user 60. The LEDs correspond to outputs A to C (see *Table 8*).

**Location 14 - codes 61 to 70, output enable.** This location has 10 segments of feature selection data. When you activate outputs with a user code (event #30), you can use Location 14 to restrict certain codes from activating certain outputs. Segment 1 corresponds to user 61; Segment 10 corresponds to user 70. The LEDs correspond to outputs A to C (see *Table 8*).

**Location 15 - codes 71 to 80, output enable.** This location has 10 segments of feature selection data. When you activate outputs with a user code (event #30), you can use Location 15 to restrict certain codes from activating certain outputs. Segment 1 corresponds to user 71; Segment 10 corresponds to user 80. The LEDs correspond to outputs A to C (see *Table 8*).

**Location 16 - codes 81 to 90, output enable.** This location has 10 segments of feature selection data. When you activate outputs with a user code (event #30), you can use Location 16 to restrict certain codes from activating certain outputs. Segment 1 corresponds to user 81; Segment 10 corresponds to user 90. The LEDs correspond to outputs A to C (see *Table 8* on page 13.)

**Location 17 - codes 91 to 99, output enable.** This location has nine segments of feature selection data. When you activate outputs with a user code (event #30), you can use Location 17 to restrict certain codes from activating certain outputs. Segment 1 corresponds to user 91; Segment 9 corresponds to user 99. The LEDs correspond to outputs A to C (see *Table 8* on page 13).

**Location 18 - A/C delay and dynamic battery test.** This location has two segments of feature selection data. Use this location to enable the A/C delay and the dynamic battery test, both of which are timed in minutes. The factory default is 5-0, meaning the A/C power will be off for 5 minutes before a report is sent or a Service light will illuminate, and the dynamic battery test is disabled (0 minutes). If you want the A/C delay to be 8 minutes and the dynamic battery test to be 3 minutes, you would program 8, 3.

**Location 19 - device options.** This location has eight segments of feature selection data. Use this location to enable various system features of the power supply module. The LEDs are described in *Table 9*.

Table 9. Output enable

LED	Description
1	On for AC report always sent; Off follows control. <ul style="list-style-type: none"> <li>• If On, an AC fail report will be sent if power is lost for the time programmed in Location 18.</li> <li>• If Off, the report will only be sent if the control panel has not sent an AC power lost report, and AC fail report is enabled in Location 37 of the panel.</li> </ul>
2	On for enables periodic battery test. Enables battery missing every 30 seconds.
3	On enables low battery reporting. If enabled, the power supply module will report a low battery warning to the central station.
4	On enables siren tamper/trouble reporting. If enabled, the power supply module will report a siren tamper to the central station.
5 to 8	Reserved.

## Programming worksheets

Use *Table 10* to program Locations 1 to 7. Use the *Data* column to enter your programming information.

Table 10. Worksheet for Locations 0 to 7

Location	Description	Default	Data
0	<a href="#">Location 0 - event and time for output A</a> on page 11	0, 10	
1	<a href="#">Location 1 - special features for output A</a> on page 12		
	<b>Segment 1</b> 1. On if timed in minutes; <i>Off</i> if timed in seconds. 2. On if latched until code is entered; <i>Off</i> for timed. 3. On if output should stop time when a code is entered (default). 4. On for inverted output. 5. On disables output during listen-in. 6-8. Reserved	3	
	<b>Segment 2</b> 1 = Partition 1   2 = Partition 2   3 = Partition 3   4 = Partition 4 5 = Partition 5   6 = Partition 6   7 = Partition 7   8 = Partition 8	1, 2, 3, 4, 5, 6, 7, 8	
2	<a href="#">Location 2 - event and time for output B</a> on page 12	0, 10	
3	<a href="#">Location 3 - special features for output B</a> on page 12		
	<b>Segment 1</b> 1. On if timed in minutes; <i>Off</i> if timed in seconds. 2. On if latched until code is entered; <i>Off</i> for timed. 3. On if output should stop time when a code is entered (default). 4. On for inverted output. 5. On disables output during listen-in. 6-8. Reserved	3	
	<b>Segment 2</b> 1 = Partition 1   2 = Partition 2   3 = Partition 3   4 = Partition 4 5 = Partition 5   6 = Partition 6   7 = Partition 7   8 = Partition 8	1, 2, 3, 4, 5, 6, 7, 8	
4	<a href="#">Location 4 - event and time for output C</a> on page 12	0, 10	
5	<a href="#">Location 5 - special features for output C</a> on page 12		
	<b>Segment 1</b> 1. On if timed in minutes; <i>Off</i> if timed in seconds. 2. On if latched until code is entered; <i>Off</i> for timed. 3. On if output should stop time when a code is entered (default). 4. On for inverted output. 5. On disables output during listen-in. 6-8. Reserved	4	
	<b>Segment 2</b> 1 = Partition 1   2 = Partition 2   3 = Partition 3   4 = Partition 4 5 = Partition 5   6 = Partition 6   7 = Partition 7   8 = Partition 8	1, 2, 3, 4, 5, 6, 7, 8	
6	<a href="#">Location 6 - event and time for the bell output</a> on page 12	16, 0	

Table 10. Worksheet for Locations 0 to 7 (continued)

Location	Description	Default	Data
7	<i>Location 7 - special features for the bell output</i> on page 12		
	<b>Segment 1</b> 1. On if timed in minutes; Off if timed in seconds. 2. On if latched until code is entered; Off for timed. 3. On if output should stop time when a code is entered (default). 4. On for inverted output. 5. On disables output during listen-in. 6-8. Reserved	3, 5	
	<b>Segment 2</b> 1 = Partition 1   2 = Partition 2   3 = Partition 3   4 = Partition 4 5 = Partition 5   6 = Partition 6   7 = Partition 7   8 = Partition 8	1, 2, 3, 4, 5, 6, 7, 8	



Table 11. Worksheet for Locations 8 to 17 (continued)

Location	Description										
14	<i>Location 14 - codes 61 to 70, output enable</i> on page 13										
	User	61	62	63	64	65	66	67	68	69	70
	Output #A	1	1	1	1	1	1	1	1	1	1
	Output #B	2	2	2	2	2	2	2	2	2	2
	Output #C	3	3	3	3	3	3	3	3	3	3
15	<i>Location 15 - codes 71 to 80, output enable</i> on page 13										
	User	71	72	73	74	75	76	77	78	79	80
	Output #A	1	1	1	1	1	1	1	1	1	1
	Output #B	2	2	2	2	2	2	2	2	2	2
	Output #C	3	3	3	3	3	3	3	3	3	3
16	<i>Location 16 - codes 81 to 90, output enable</i> on page 14										
	User	81	82	83	84	85	86	87	88	89	90
	Output #A	1	1	1	1	1	1	1	1	1	1
	Output #B	2	2	2	2	2	2	2	2	2	2
	Output #C	3	3	3	3	3	3	3	3	3	3
17	<i>Location 17 - codes 91 to 99, output enable</i> on page 14										
	User	91	92	93	94	95	96	97	98	99	
	Output #A	1	1	1	1	1	1	1	1	1	
	Output #B	2	2	2	2	2	2	2	2	2	
	Output #C	3	3	3	3	3	3	3	3	3	

Use *Table 12* to program Locations 18 and 19. Use the *Data* column to enter your programming information.

Table 12. Worksheet for Locations 18 and 19

Location	Description	Default	Data
18	<i>Location 18 - A/C delay and dynamic battery test</i> on page 14	5 0	
19	<i>Location 19 - device options</i> on page 14 1. On for AC report always sent; Off follows control 2. On enables periodic battery test 3. On enables low battery reporting 4. On enables siren tamper/trouble reporting 5 to 8. Reserved.	2, 3, 4	

## Specifications

Dimensions	2.0 × 4.0 in.
Current draw	
AC input	120 V 60 Hz, 650 mA
Standby	10 mA VA
Transformer	16.5 VAC 50 VA
Auxiliary power	
VA	Limited to 2.0 A
Battery	51 Ah for 24 hours of battery backup 5 to 17 Ah in parallel
Operating temperature	32 to 120°F (0 to 49°C)
Shipping weight	8 lb. (3.63 kg)
Compatible control panels	NX-8 48 Zone Household Fire & Burglary or NX8V2 Commercial Burglary Control NX-8-CF 48 Zone Commercial Fire Control NX-8E 192 Zone Household Fire & Burglary, Commercial Burglary Control NX-8E-CF. 192 Zone Commercial Fire Control

## Contacting us

For help installing, operating, maintaining, and troubleshooting this product, refer to this document and any other documentation provided. If you still have questions, contact us during business hours (Monday through Friday, excluding holidays, between 5 a.m. and 5 p.m. Pacific Time).

Table 13. Technical support

<b>North America</b>	<b>Latin America</b>
T: 888 GE Security (888.437.3287) Toll-free in the US, Puerto Rico, and Canada. 503.885.5700 outside the toll-free area.	T: 305.593.4301
F: 561.998.6232 (Boca Raton tech support)	F: 305.593.4300
E: <a href="mailto:nstechsrv@ge.com">nstechsrv@ge.com</a> <a href="mailto:gesecurity.customerservice@ge.com">:gesecurity.customerservice@ge.com</a>	E: <a href="mailto:InfraSec.TechnicalServicesLatinAmerica@ge.com">InfraSec.TechnicalServicesLatinAmerica@ge.com</a> <a href="mailto:InfraSecCustomerService.LatinAmerica@ge.com">InfraSecCustomerService.LatinAmerica@ge.com</a>
<b>Australia, New Zealand</b>	<b>Europe, Middle East, and Africa</b>
E: <a href="mailto:techsupport@gesecurity.com.au">techsupport@gesecurity.com.au</a>	W: At <a href="http://www.gesecurity.eu">www.gesecurity.eu</a> , select <i>Customer Support</i> .
	<b>China, India, Singapore, Taiwan, Southeast Asia</b>
	E: <a href="mailto:ges.asiatechservice@ge.com">ges.asiatechservice@ge.com</a>

**Note:** Be ready at the equipment before calling.

## Online resources

Here are some useful links on our website [www.gesecurity.com](http://www.gesecurity.com):

**Online library.** From the *Customer Support* menu, select the [Resource Library](#) link. After you register and log on, you may search for the documentation you need.<sup>1</sup>

**Training.** To view any available online training for GE Security products, select the [Training](#) link. (Online training is not available for all products.)

**Warranty and terms information.** From the *Customer Support* menu, select [Return and Warranty Policy Statement](#) or [Terms and Conditions Policy Statement](#).

**Customer service and technical support.** From the *Customer Support* menu, select [Customer Service](#) or [Technical & Application](#). Select the appropriate product category for the contact information or use the menu to select a location outside the US.

1. Many GE documents are provided in English only as PDFs. To read these documents, you will need Adobe Reader, which you can download free from Adobe's website at [www.adobe.com](http://www.adobe.com).