

## Installation Instructions

---

This document describes the installation, programming, testing, and troubleshooting procedures for installing a Concord security system.

### **About This Manual ..... 5**

Special Installation Requirements .....	5
UL-Listed Installations .....	5
UL-Canada Listed Installations .....	6
California State Fire Marshall Listed Installations	6

### **Planning the Installation..... 6**

Standard Panel .....	6
Touchpads .....	7
SuperBus RF Receivers .....	7
Power Line Carrier Card.....	7
Supervised Wireless Siren .....	7
Phone Interface/Voice Module .....	7
SnapCards .....	7
SuperBus Hardwire Input Module .....	7
SuperBus Hardwire Output Module .....	7
Interrogator 200 Audio Verification Module.....	8

### **Installing the System ..... 8**

Determine the Panel Location.....	8
Total System Power and Wire Length Guidelines .....	8
Mounting the Panel .....	10
Identify Panel Components.....	10
Connecting the Panel to Earth Ground .....	10
Installing the Optional Power Line Carrier Card (60-755) .....	11
Installing Optional SnapCards .....	11
Connecting Detection Devices to Panel Zone Inputs .....	11
Connecting 2-Wire Smoke Detectors .....	12
Connecting Speakers.....	12
15-Watt Speaker (13-060) .....	12
Hardwire Interior Speaker (60-528) .....	12
Connecting Piezo Sirens .....	13
Hardwire Exterior Siren (13-046).....	13
Slim Line Hardwire Interior Siren (60-483-01).....	13
Output 1 .....	14
Connecting an Interrogator 200 (60-677) .....	14

Connecting Alphanumeric and LED Touchpads .....	14
Installing SuperBus Modules .....	14
SuperBus RF Receiver (60-764-95R).....	15
Phone Interface/Voice Module (60-777) .....	16
Energy Saver Module (60-620) .....	17
Hardwire Input Module (60-584) .....	17
Hardwire Output Module (60-585).....	18
Setting Device Address DIP Switches on Bus Devices.....	18
Installing an RJ-31X Phone Jack (13-081) .....	19
Connecting the Phone Line to the Panel with a DB-8 Cord.....	20
Connecting the AC Power Transformer.....	21
Power Up the Panel.....	21

### **Programming the Panel..... 22**

Setting Alphanumeric Touchpad Device Addresses .....	22
Entering Program Mode.....	22
Touchpad Button Programming Functions .....	22
Moving Through Program Mode Tiers and Menus .....	23
Programming Tier 1 Menu Items.....	23
Programming Tier 2 Menu Items.....	24
Using Shortcut Numbers.....	24
Security Menu .....	25
Phones Menu.....	27
Phone Options Menu .....	30
Timers Menu.....	32
Light Control Menu .....	35
Touchpad Options Menu .....	36
Reporting Menu .....	37
Siren Options Menu .....	41
Sensors Menu.....	42
Audio Verification Menu.....	45
Accessory Modules Menu .....	46
Onboard Options Menu .....	49
Wireless Touchpads Menu.....	54
Entering User Programming Mode .....	54
User Codes Menu.....	55
Time and Date Menu .....	56
Set Up Schedules Menu.....	56

Attach Schedules to Events Menu .....	57
Options Menu .....	58
System Version Menu.....	59
Energy Saver Menu .....	60

**Testing the System..... 61**

Basic System Commands.....	61
Testing Zones/Sensors .....	62
If a Zone/Sensor Does Not Test.....	62
Testing Phone Communication.....	62
Testing Central Station/Pager Communication.....	63
Testing Outputs .....	63
Testing Light Control.....	63
Testing the Energy Saver Module.....	64
Downloader Programming .....	64
ToolBox Downloader	
Programming .....	64

**Troubleshooting ..... 65**

Panel Power .....	66
Access Codes .....	67
Arming and Disarming .....	68
Bypassing .....	68
Wireless Sensor and Touchpad Batteries .....	69
Central Station/Pager Reporting .....	69
Alphanumeric Touchpads .....	70
LED Touchpads .....	70
Speakers .....	71
Piezo Sirens .....	71
Supervised Wireless Sirens .....	72
Hardwire Zones .....	72
Wireless Sensor Zones .....	73
Wireless Touchpads .....	74
Phones .....	74
Light Control .....	75

**AppendixA:SystemPlanningWorksheets  
77**

**Programming Mode Menus  
and Settings ..... 81**

**System Wiring Diagram.....Back Page**

# Notices

This manual may refer to products that are announced but are not yet available.

## FCC Notices

This equipment has been tested and found to comply with the limits for a class B digital device, pursuant to part 15 of the FCC rules. These limits are designed to provide reasonable protection against harmful interference in a residential installation. This equipment generates, uses, and can radiate radio frequency energy and, if not installed and used in accordance with the instructions, may cause harmful interference to radio communications. However, there is no guarantee that interference will not occur in a particular installation. If this equipment does cause harmful interference to radio or television reception, which can be determined by turning the equipment off and on, the user is encouraged to try to correct the interference by one or more of the following measures:

- Install a quality radio or television outdoor antenna if the indoor antenna is not adequate.
- Reorient or relocate the panel.
- Move the panel away from the affected equipment.
- Move the panel away from any wire runs to the affected equipment.
- Connect the affected equipment and the panel to separate outlets, on different branch circuits.
- Consult the dealer or an experienced radio/TV technician for help.
- Send for the FCC booklet *How to Identify and Resolve Radio-TV Interference Problems*, available from the U.S. Government Printing Office, Washington, D.C. 20402. Stock Number: 004-000-00345-4.

This device complies with part 15 of the FCC rules. Operation is subject to the following two conditions: (1) this device may not cause harmful interference, and (2) this device must accept any interference received, including interference that may cause undesired operation.

This equipment complies with part 68 of the FCC rules. On the FCC label affixed to this equipment is the FCC Registration Number and Ringer Equivalence Number (REN) for this equipment. If requested, provide this information to your telephone company.

The REN is used to calculate the maximum number of devices your telephone line will support with ringing service. In most areas the sum of all device RENs should not exceed 5.0. Contact your local telephone company to determine the maximum REN for your calling area.

If your telephone equipment causes harm to the telephone network, your telephone company may temporarily disconnect your service. If possible, you will be notified in advance. When advance notice is not practical, you will be notified as soon as possible. You will also be advised of your right to file a complaint with the FCC.

Your telephone company may make changes in its facilities, equipment, operations, or procedures that could affect the proper operation of your equipment. You will be given advanced notice in order to maintain uninterrupted service.

If you experience trouble with this equipment, please contact

**Interactive Technologies, Inc.**  
**2266 Second Street North**  
**North Saint Paul, MN 55109**  
**1-800-777-1415**

for service and repair information. The telephone company may ask you to disconnect this equipment from the network until the problem has been corrected or until you are sure that the equipment is not malfunctioning.

This equipment may not be used on coin service provided by the telephone company. Connection to party lines is subject to state tariffs.

## Canada Notice

The Canadian Department of Communications label identifies certified equipment. This certification means that the equipment meets certain telecommunications network protective, operational, and safety requirements. The department does not guarantee the equipment will operate to the user's satisfaction.

Before installing this equipment, users should ensure that it is permissible to be connected to the facilities of the local telecommunications company. The equipment must also be installed using an acceptable method of connection. In some cases, the company's inside wiring associated with a single-line individual service may be extended by means of a certified connector assembly (telephone extension cord). The customer should be aware that compliance with the above conditions may not prevent degradation of service in some situations.

Repairs to certified equipment should be made by an authorized Canadian maintenance facility designated by the supplier. Any repairs or alterations made by the user to this equipment, or equipment malfunctions, may give the telecommunications company cause to request the user to disconnect the equipment.

For your protection, make sure that the electrical ground connections of the power utility, telephone lines, and internal metallic water pipe system, if present, are connected together.

## Caution

**Do not attempt to make connections yourself. Contact the appropriate electrician or electric inspections authority.**

The Load Number (LN) assigned to each terminal device denotes the percentage of the total load to be connected to a telephone loop that is used by the device to prevent overloading. The termination on a loop may consist of any combination of devices subject only to the requirement that the total of the LNs of all the devices does not exceed 100. Load Number: 0.4B

“AVIS: - L'étiquette du ministère des Communications du Canada identifie le matériel homologué. Cette étiquette certifie que le matériel est conforme a certaines normes de protection, d'exploitation et de sécurité des réseaux de télécommunications. Le ministère n'assure toutefois pas que le matériel fonctionnera a la satisfaction de l'utilisateur.

Avant d'installer ce matériel, l'utilisateur doit s'assurer qu'il est permis de le raccorder aux installations de l'entreprise locale de télécommunication. Le matériel doit également être installé en suivant une méthode acceptée de raccordement. Dans certains cas, les fils intérieurs de l'entreprise utilisés pour un service individuel a ligne unique peuvent être prolongés au moyen d'un dispositif homologué de raccordement (cordon prolongateur téléphonique interne). L'abonné ne doit pas oublier qu'il est possible que la conformité aux conditions énoncées ci-dessus n'empêchent pas le dégradation du service dans certaines situations. Actuellement, les entreprises de télécommunication ne permettent pas que l'on raccorde leur matériel a des jacks d'abonné, sauf dans les cas précis prévus par les tarifs particuliers de ces entreprises.

Les réparations de matériel homologué doivent être effectuées par un centre d'entretien canadien autorisé désigné par le fournisseur. La compagnie de télécommunications peut demander a l'utilisateur de débrancher un appareil a la suite de réparations ou de modifications effectuées par l'utilisateur ou a cause de mauvais fonctionnement.

Pour sa propre protection, l'utilisateur doit s'assurer que tous les fils de mise a la terre de la source d'énergie électrique, des lignes téléphoniques et des canalisations d'eau métalliques, s'il y en a, sont raccordés ensemble. Cette précaution est particulièrement importante dans les régions rurales.

**Avertissement. - L'utilisateur ne doit pas tenter de faire ces raccordements lui-même; il doit avoir recours a un service d'inspection des installations électriques, ou a un electricien, selon le cas”.**

Une note explicative sur les indices de charge (voir 1.6) et leur emploi, a l'intention des utilisateurs du matériel terminal, doit être incluse dans l'information qui accompagne le matériel homologué. La note pourrait être rédigée selon le modèle suivant:

“L'indice de charge (IC) assigné a chaque dispositif terminal indique, pour éviter toute surcharge, le pourcentage de la charge totale qui peut être raccordée a un circuit téléphonique bouclé utilisé par ce dispositif. La terminaison du circuit bouclé peut être constituée de n'importe quelle somme des indices de charge de l'ensemble des dispositifs ne dépasse pas 100.”

L'Indice de charge de cet produit est \_\_\_\_\_.

## Trademarks

ITI is a registered trademark of Interactive Technologies, Inc. Concord, SuperBus, SnapCard, and ToolBox are trademarks of Interactive Technologies, Inc. X-10 is a registered trademark of X-10 (USA), Inc.



**INTERACTIVE TECHNOLOGIES, INC.**

2266 SECOND STREET NORTH  
NORTH SAINT PAUL, MN 55109

T: 651/777-2690

F: 651/779-4890

W I R E L E S S

Security

Automation

Access Control

## About This Manual

---

This manual provides information for planning, installing, programming, and testing this security system. When necessary, this manual refers you to other documentation included with the compatible peripherals.

Planning sheets are included for you to record hardware layout and software programming settings.

## Special Installation Requirements

---

This security system can be used as a fire warning system, an intrusion alarm system, an emergency notification system, or any combination of the three.

Some installations may require configurations dictated by city/state codes, insurance, or Underwriter's Laboratories (UL) requirements. This section describes the various component and configuration listings.

## UL-Listed Installations

---

This section describes the requirements for UL Listed installations.

### Basic System

- Control Panel (60-734)
- SuperBus 8Z LED Touchpad (60-728) or SuperBus 2x16 LCD Touchpad (60-746)
- Standard Class II 24 VAC, 30 VA Power Transformer (60-761), Class II 24 VAC, 30 VA Line Carrier Power Transformer (60-762), or Standard Class II 24 VAC, 50 VA Power Transformer (60-778), Class II 24 VAC, 50 VA Line Carrier Power Transformer (60-779)
- Interior Speaker Siren (60-528) or Exterior Speaker Siren (13-060)

Basic system may also include a SuperBus RF Receiver (60-764-95R-16 or -32).

## Household Burglary Alarm System Unit (UL 1023)

Basic system, plus:

- Hardwire Magnetic Contact (13-068 or 13-071) or Wireless Learn Mode Door/Window Sensor (60-362)
- IMMEDIATE TROUBLE BEEPS set to on
- UL 98 OPTIONS set to on
- RECEIVER FAILURE set to on
- RF TX TIMEOUT set to 24 hours (if system includes SuperBus RF Receiver and wireless smoke sensors)

## Household Fire Warning System (UL 985)

Basic system, plus:

- Hardwire Smoke Detector: System Sensor models 2100, 2100T, 2400, or 2400T learned into Sensor Group 26 Sentrol models 429C, 429CT, 521B, or 521BXT learned into sensor group 26
- Wireless Smoke Sensor 60-506-319.5 or 60-645-95 learned into sensor group 26
- IMMEDIATE TROUBLE BEEPS set to on
- UL 98 OPTIONS set to on
- RECEIVER FAILURE set to on
- RF TX TIMEOUT set to 4 hours (if system includes SuperBus RF Receiver and wireless smoke sensors)

## 24-Hour Backup

- For 24-hour backup, the total current draw for all connected devices is limited to 100 mA continuous using a 4.0 AH battery, or 200 mA continuous using a 7.0 AH battery.

## Commercial Burglary Alarm System Unit (UL 1610)

Basic system, plus:

- Hardwire Magnetic Contact (13-068 or 13-071) or Wireless Learn Mode Door/Window Sensor (60-362)

## Central Station Reporting

The panel has been tested with the following central station receivers using SIA and Contact ID reporting formats:

## Planning the Installation

- ITI CS-5000 Central Station Receiver
- Sur-Gard Central Station Receiver with models SG-DRL2A and SG-CPM2

## UL-Canada Listed Installations

---

This section describes the requirements for ULC (UL Canada) Listed installations.

### CSA Certified Accessories

#### Residential Burglary Alarm System Unit (ULC-S309)

Basic system as described for “UL-Listed Installations” plus:

- Hardwire Magnetic Contact (13-068 or 13-071) or Wireless Learn Mode Door/Window Sensor (60-362)

#### Residential Fire Warning System Control Unit (ULC-S545-M89)

Basic system as described for “UL-Listed Installations” plus:

- Hardwire Smoke Detector: System Sensor models 2100, 2100T, 2400, 2400T learned into Sensor Group 26, or Sentrol models 429C, 429CT, 521B, or 521BXT learned into sensor group 26
- Wireless Smoke Sensor 60-506-319.5 or 60-645-95 learned into sensor group 26.
- IMMEDIATE TROUBLE BEEPS set to on
- RF TX TIMEOUT set to 4 hours (if system includes SuperBus RF Receiver and wireless smoke sensors).

#### Note

For 24-hour backup, external power drain is limited to 100 mA continuous using a 4.0AH battery, or 200 mA continuous using a 7.0AH battery.

## California State Fire Marshall Listed Installations

---

The California State Fire Marshall listing is pending.

## Planning the Installation

---

This section describes the systems’ capabilities to help you get familiar with the system. Appendix A provides planning sheets with tables that let you record the hardware and programming configuration of the system. Fill in all necessary information ahead of time to help prepare for system installation.

## Standard Panel

---

The following describes the panel’s basic (out-of-box) hardware capabilities.

- **Power:** Input for an AC step-down, plug-in style transformer.
- **Auxiliary Power Output:** Output that supplies 1 amp (with panel powered by 30 VA transformer) or 2 amps (with panel powered by 50 VA transformer) at 12 VDC for bus devices and hardwired detectors, such as hardwired motion detectors.
- **Bus A and B:** Input and output that provides communication between bus devices and the panel.
- **Siren Driver:** Output that can drive an 8-ohm load and provides intrusion and fire alarm sounds for partition 1.
- **2 Onboard Outputs:** Open-collector outputs that can be set up to activate other signalling devices, based on system events.
- **Microphone Input:** Input used for 2-way audio when used in conjunction with the Interrogator 200 Audio Verification Module.
- **8 Supervised Hardwire Zones:** Inputs for various hardwired detectors. Zone 8 can be set up in programming to accept 2-wire smoke detectors.
- **Phone Line Connection:** Allows panel to communicate with central monitoring station and/or pagers.

## Touchpads

---

The following describes the different touchpads that can be used for system programming and operation.

- **SuperBus 8Z LED Touchpad:** Provides control for basic system operation. LEDs indicate status for 8 zones, arming (STAY, AWAY), alarm and trouble conditions, bypassed zones, and power.
- **SuperBus 2x16 LCD Touchpad:** Provides complete system programming and operation control. Displays system messages that prompt users for information when needed and indicates system status.

## SuperBus RF Receivers

---

These receivers expand the system's wireless zone capacity by 16 or 32 zones and are compatible with all ITI 319.5 MHz. Learn Mode wireless sensors and touchpads, and also allow for supervision of Supervised Wireless Sirens.

## Power Line Carrier Card

---

Adding this card (which requires that the panel be powered using a Power Line Carrier Transformer) adds the following capabilities to the system:

- Allows the use of Supervised Wireless Sirens.
- Allows the use of X-10 Powerhouse Lamp Modules for light control and light activation during alarms.

## Supervised Wireless Siren

---

Supervised Wireless Sirens plug into any standard electrical outlet and produce status and alarm sounds. The panel sends signals to the siren through the Power Line Carrier Card and Line Carrier Power Transformer, through the AC electrical wiring.

The siren has a built-in transmitter that is used for su-

perceiving the siren. With a SuperBus RF Receiver installed and the siren transmitter learned into panel memory, the siren can notify the panel if it is unplugged, stops receiving panel signals, or has a low backup battery.

## Phone Interface/Voice Module

---

This module allows system access and control using touch-tone telephones, on- or off-site. The module includes an output for a speaker that sounds system status and alarm voice messages.

## SnapCards

---

The following SnapCards expand the system as described:

- **8Z Input SnapCard:** Provides eight additional hardwire zone inputs, of which two are dedicated for using 2-wire smoke detectors.
- **4 Output SnapCard:** Provides four form C relay outputs that can be set up to activate other signalling devices, based on system events.
- **4Z Input/2 Output Combo SnapCard:** Provides four hardwire zone inputs and two outputs that can be set up to activate other signalling devices, based on system events.

## SuperBus Hardwire Input Module

---

Provides eight additional hardwire zone inputs.

## SuperBus Hardwire Output Module

---

Provides four form C relay outputs that can be set up to activate other signalling devices, based on system events.

## Interrogator 200 Audio Verification Module

Adding this module allows central station operators to listen-in and talk to occupants on the premises, to verify the emergency when an alarm report is received.

## Installing the System

This section describes how to install the system control panel. Before starting the installation, plan your system layout and programming using the worksheets provided in Appendix A.

Installing the system consists of the following:

- Determining the Panel Location
- Total System Power and Wire Length Guidelines
- Mounting the Panel
- Identifying Panel Main Components
- Installing the Optional Power Line Carrier Card
- Installing Optional SnapCards
- Connecting Detection Devices to Panel Zone Inputs
- Connecting Speakers
- Connecting Piezo Sirens
- Connecting a Garage Door Opener
- Connecting an Interrogator 200
- Connecting Alphanumeric and LED Touchpads
- Installing SuperBus Modules
- Setting Unit Number DIP Switches on SuperBus Devices
- Installing an RJ-31X Phone Jack
- Connecting the Phone Line to the Panel with a DB-8 Cord
- Connecting the AC Power Transformer
- Powering Up the Panel

## Determine the Panel Location

Before permanently mounting the panel, determine panel location using the following guidelines:

- Centrally locate the panel with relation to detection devices whenever possible, to help reduce

wire run lengths and labor.

- Avoid running wires parallel with electrical wiring or fixtures such as fluorescent lighting, to prevent wire runs from picking up electrical noise.
- Mount the panel at a comfortable working height (about 45 to 55 inches from the floor to the bottom of the panel, as shown in Figure 1).
- Leave space to the left and right of the panel for wiring, phone jack, and mounting optional modules.
- Allow at least 9 inches above the panel for antennas, if the system includes a SuperBus RF Receiver.
- Allow at least 24 inches in front of the panel to open the panel door.

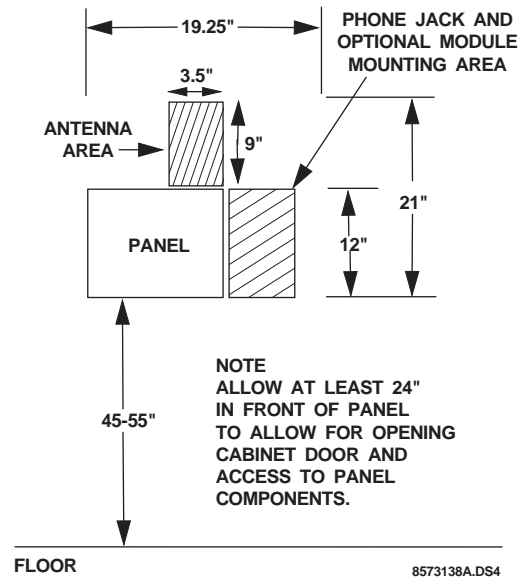

Figure 1. Determining Panel Location

## Total System Power and Wire Length Guidelines

The panel can supply up to 1 amp (1,000 mA) when powered by the 24 VAC, 30 VA transformer or up to 2 amps (2,000 mA) when powered by the 24 VAC, 50 VA transformer for system devices.

The total system wire allowed can vary depending on devices powered by the panel, the wire length between devices and the panel, and the combined wire length of all devices.



Table 1 describes the maximum wire length allowed between compatible devices and the panel, including the maximum current draw of each device.

**Table 1. Maximum Device Wire Length and Current Draw**

Device	Max. Wire Length to Panel	Max. mA Draw
SuperBus 2x16 LCD Alphanumeric Touchpad	22 ga.—300 ft. 18 ga.—750 ft.	90 mA
SuperBus 8Z LED Touchpad	22 ga.—300 ft. 18 ga.—700 ft.	65 mA
SuperBus RF Receiver	22 ga.—1,100 ft. 18 ga.—2,800 ft.	30 mA
SuperBus Phone Interface/Voice Module	22 ga.—40 ft. 18 ga.—120 ft.	600 mA
Power Line Carrier Card	N/A	110 mA
4 Inpu/2 Output SnapCard	N/A	185 mA
8Z Hardwire Zone Expander SnapCard	N/A	230 mA
4 Output SnapCard	N/A	130 mA
SuperBus Hardwire Input Module	22 ga.—1,800 ft. 18 ga.—4,500 ft.	18 mA
SuperBus Hardwire Output Module	22 ga.—350 ft. 18 ga.—900 ft.	91 mA
SuperBus Energy Saver Module	22 ga.—1,600 ft. 18 ga.—4,000 ft.	20 mA
Interrogator 200	22 ga.—3,200 ft. 18 ga.—4,500 ft.	10 mA
Interrogator AVM	22 ga.—110 ft. 18 ga.—260 ft.	300 mA

Table 2 describes the total system wire lengths allowed when installing systems with or without LED touchpads, using unshielded or shielded cable.

**Table 2. Total System Wire Length Allowed**

Wire Type	Total System Wire for Systems with LED Touchpads	Total System Wire for Systems without LED Touchpads
22-gauge, unshielded	2,000 ft.	4,500 ft.
22-gauge, shielded	1,300 ft.	3,000 ft.
18-gauge, unshielded	1,600 ft.	3,500 ft.
18-gauge, shielded	900 ft.	2,200 ft.

Table 3 describes the minimum current draw of each device when the panel is operating only from the backup battery. For 24-hour backup, the total current draw of all connected devices is limited to 100 mA continuous using a 4.0 AH battery, or 200 mA continuous using a 7.0 AH battery.

**Table 3. Minimum Device Current Draw**

Device	Min. mA Draw
SuperBus 2x16 LCD Alphanumeric Touchpad	15 mA
SuperBus 8Z LED Touchpad	15 mA
SuperBus RF Receiver	27 mA
SuperBus Phone Interface/Voice Module	25 mA
Power Line Carrier Card	N/A
4 Inpu/2 Output SnapCard	20 mA
8Z Hardwire Zone Expander SnapCard	38 mA
4 Output SnapCard	1 mA
SuperBus Hardwire Input Module	18 mA
SuperBus Hardwire Output Module	11 mA
SuperBus Energy Saver Module	20 mA
Interrogator 200	10 mA
Interrogator AVM	45 mA

After determining panel location, run all necessary wires to that location using the guidelines in Table 4.

**Table 4. Device Wiring Requirements**

Device	Wire Requirements
AC Power Transformer	2-conductor, 18-gauge, 25 feet maximum
Earth Ground	Single conductor, 16-gauge solid, 25 feet maximum
Telephone (RJ-31X)	4-conductor
Detection Devices	2- or 4-conductor, 18- to 22-gauge, 50 ohms maximum loop resistance including device
Sirens/Speakers	2-conductor, 18- 22-gauge
SuperBus Devices	4-conductor, 22- or 18-gauge
Interrogator 200 AVM Power and Microphone	4-conductor, 22-gauge, shielded

## Mounting the Panel

Use the following procedure to mount the panel to the wall or wall studs.

### Caution

Make sure you are free of static electricity whenever you work on the panel with the cover open. To discharge any static, first touch the metal panel chassis, then stay in contact with the chassis when touching the circuit board. Using an approved grounding strap is recommended.

### To mount the panel:

1. Open the panel door and remove the necessary wiring knockouts (see Figure 2). Be careful not to damage the circuit board.
2. Feed all wires through wiring knockouts and place the panel in position against the wall.
3. Level the panel and mark the top and bottom mounting holes (see Figure 2).
4. Install anchors where studs are not present.
5. Partially insert screws into the two top mounting hole locations, then hang the panel on the two screws.
6. Recheck for level, insert the two lower screws, and tighten all four mounting screws.

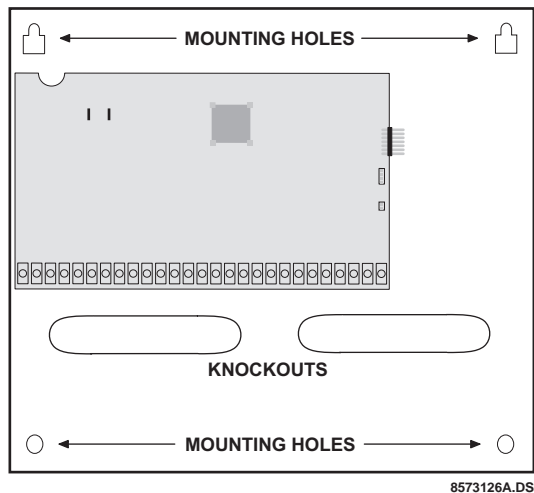

Figure 2. Mounting the Panel

## Identify Panel Components

Before installing devices and making wiring connections, familiarize yourself with the panel's main components (see Figure 3).

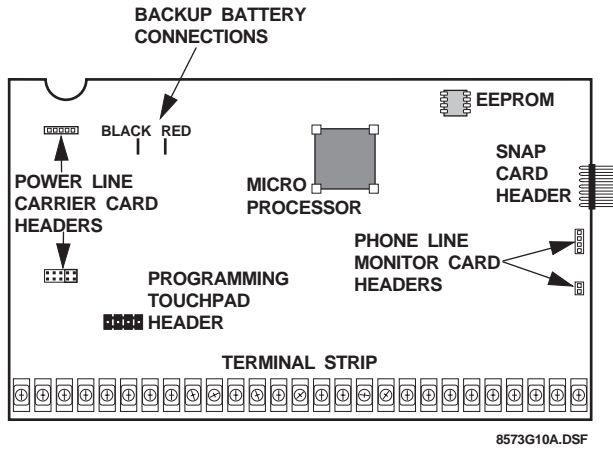

Figure 3. Main Components On the Panel

## Connecting the Panel to Earth Ground

For maximum protection from lightning strikes and transients, connect the lower-left circuit board screw to earth ground as shown in Figure 4. Use 16-gauge, solid copper wire from an earth grounded cold water pipe clamp to the panel.

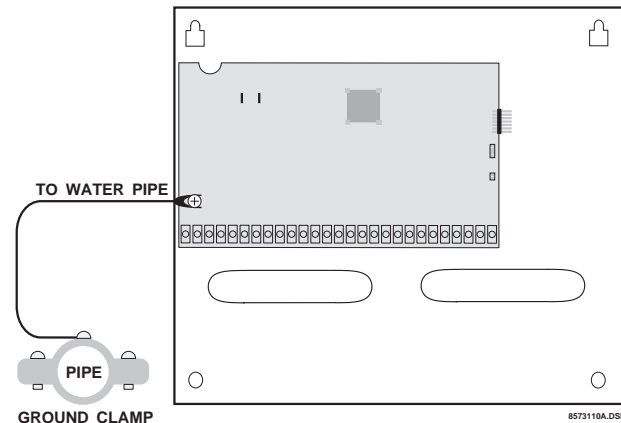

Figure 4. Connecting the Panel to Earth Ground

### Note

For best results, it is recommended that you crimp a spade lug on the wire end at the panel and secure the lug under the circuit board screw as shown in Figure 4.

## Installing the Optional Power Line Carrier Card (60-755)

The Power Line Carrier card lets you add Supervised Wireless Sirens for alarm and status sounds and X-10 Lamp Modules for controlling lights.

Install the card on the header pins as shown in Figure 5. No wiring or programming is necessary.

**Note**

The lower header has two jumpers installed from the factory that must be removed before installing the Power Line Carrier Card. Leave these jumpers in place if you are not installing a Power Line Carrier Card.

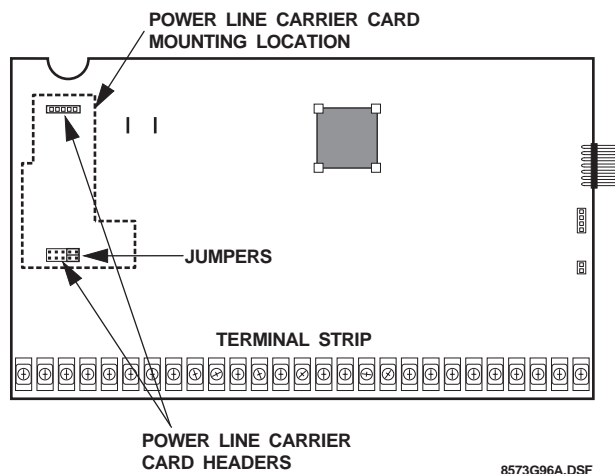

Figure 5. Installing the Power Line Carrier Card

## Installing Optional SnapCards

The SnapCard Header on the right side of the panel allows for installation of one SnapCard.

Install the desired SnapCard onto the panel's Snap-Card Header and secure it in place with two screws, included with the card (see Figure 6).

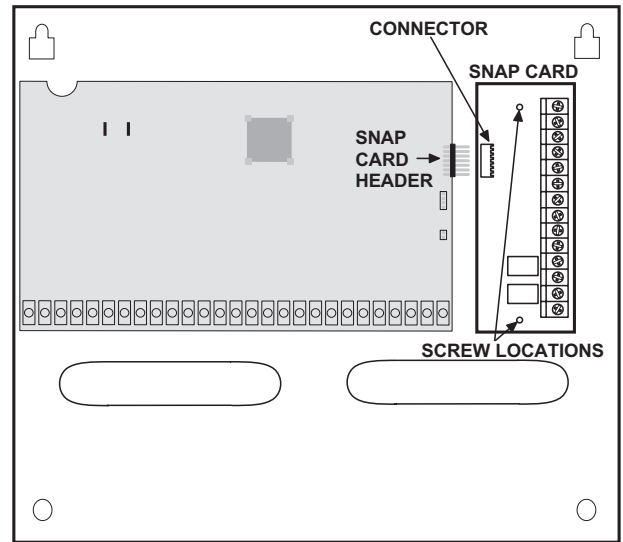

Figure 6. Installing a SnapCard into the Panel's Expansion Connector

Connect all necessary input/output wiring using the *installation instructions* included with the card.

## Connecting Detection Devices to Panel Zone Inputs

All zone inputs are supervised using a 2k-ohm, end-of-line resistor at the last device on the circuit and accept either normally open (N/O) or normally closed (N/C) detection devices. Figure 7 shows the typical wiring for N/C and N/O intrusion detection circuits.

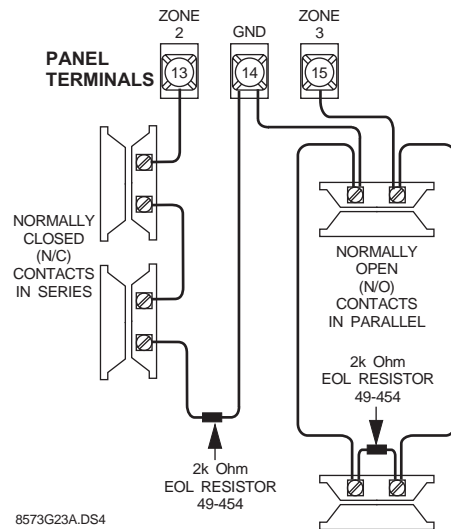

Figure 7. Connecting N/C and N/O Intrusion Detection Circuits to the Panel

## Connecting 2-Wire Smoke Detectors

Zone input 8 can be set up (in program mode) to accept 12 VDC, 2-wire smoke detectors by the following manufacturers:

- System Sensor models 2100, 2100T, 2400, 2400T
- Sentrol models 429C, 429CT, 521B, 521BXT

When zone input 8 is set up for 2-wire smoke detectors, the maximum loop current allowed is 100 mA (in alarm).

Connect up to ten 2-wire smoke detectors to the panel as shown in Figure 8.

### Note

Zone 8 must have the 2-wire smoke option turned on for 2-wire smoke detectors to operate correctly. See *ONBOARD OPTIONS—INPUTS* in the “Programming” section for complete details.

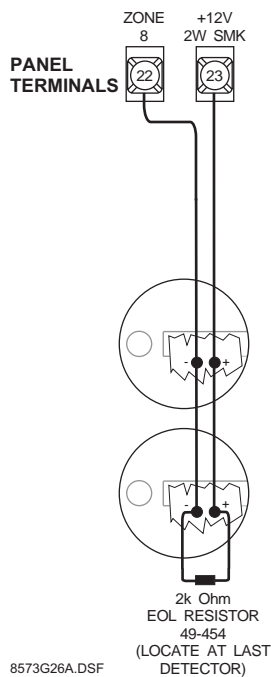

Figure 8. Connecting 2-Wire Smoke Detectors to the Panel

## Connecting Speakers

The panel provides one siren driver output for intrusion (steady), fire (temporal 3), and auxiliary (on-off-on-off) alarm sounds. This output trips only for partition 1 alarms.

The output can drive a single 8-ohm speaker or multiple speaker circuit of 8 ohms or higher (as shown in the following speaker wiring diagrams). Compatible speakers are described below.

### Caution

To avoid disabling the panel speaker output, do not make speaker connections with the panel powered up.

## 15-Watt Speaker (13-060)

Use this speaker for exterior siren applications. Connect the speaker to the panel as shown in Figure 9.

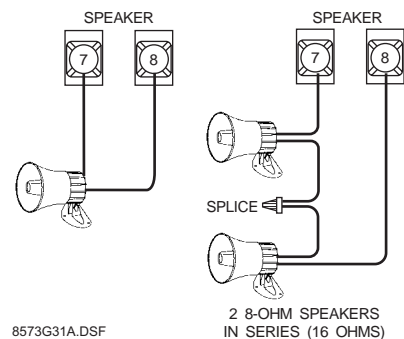

Figure 9. Connecting Speakers to the Panel

## Hardwire Interior Speaker (60-528)

Use this speaker unit for interior siren applications. Connect the speaker to the panel as shown in Figure 10.

### Caution

Connect only the large speaker to panel terminals 7 and 8 as shown. The smaller speaker cannot handle the output of terminals 7 and 8 and should not be connected, to avoid damaging the speaker.

## Connecting Piezo Sirens

Onboard output 2 (OUT 2—terminal 10) defaults to a setting that activates the output when an alarm condition occurs. This allows you to connect a piezo siren without changing the output’s configuration number in programming.

For more information on output configuration numbers, see the “Programming” section of this manual.

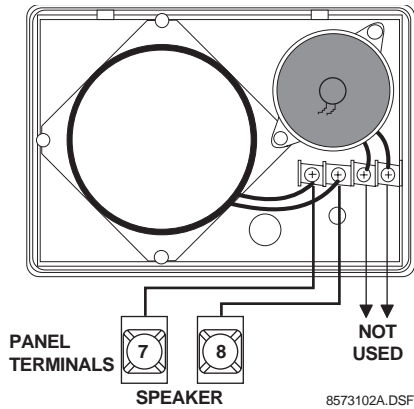

**Figure 10. Connecting the Hardwire Interior Speaker w/ Dual Speakers to the Panel**

Connect two units to the panel terminals with speakers in series (16 ohms), as shown in Figure 11.

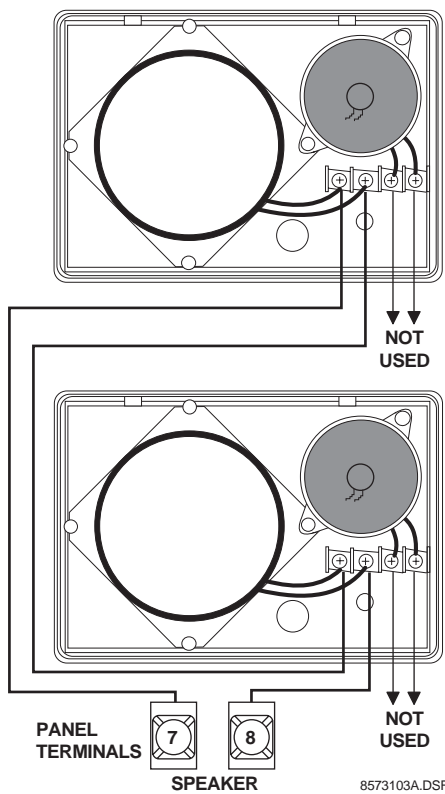

**Figure 11. Connecting Two Hardwire Interior Speaker w/ Dual Speaker Units to Panel Terminals and Phone Interface/Voice Module with Speakers in Series**

## Hardwire Exterior Siren (13-046)

Connect the siren to the panel as shown in Figure 12.

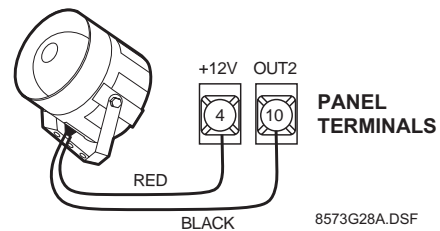

**Figure 12. Connecting the Hardwire Exterior Siren to the Panel**

## Slim Line Hardwire Interior Siren (60-483-01)

Connect the siren to the panel as shown in Figure 13.

**Note**

The volume switch settings inside the siren do not affect the siren output.

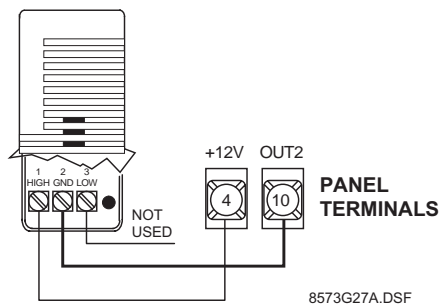

**Figure 13. Connecting the Slim Line Hardwire Interior Siren to the Panel**

## Output 1

Onboard output 1 (OUT 1—terminal 9) defaults to a setting that activates the output when the panel (using a SuperBus RF Receiver) receives a \* button press signal from a 4-Button Keychain Touchpad.

For more information on output configuration numbers, see the “Programming” section of this manual.

## Connecting an Interrogator 200 (60-677)

Connect the Interrogator 200 to the panel terminals as shown in Figure 14.

### Caution

If a speaker is already connected to panel terminals 7 and 8, the Interrogator 200 speaker must be hooked up in series with that speaker to provide a 16-ohm load. Hooking up speakers in parallel to panel terminals 7 and 8 creates a 4-ohm load that can cause permanent damage to the panel.

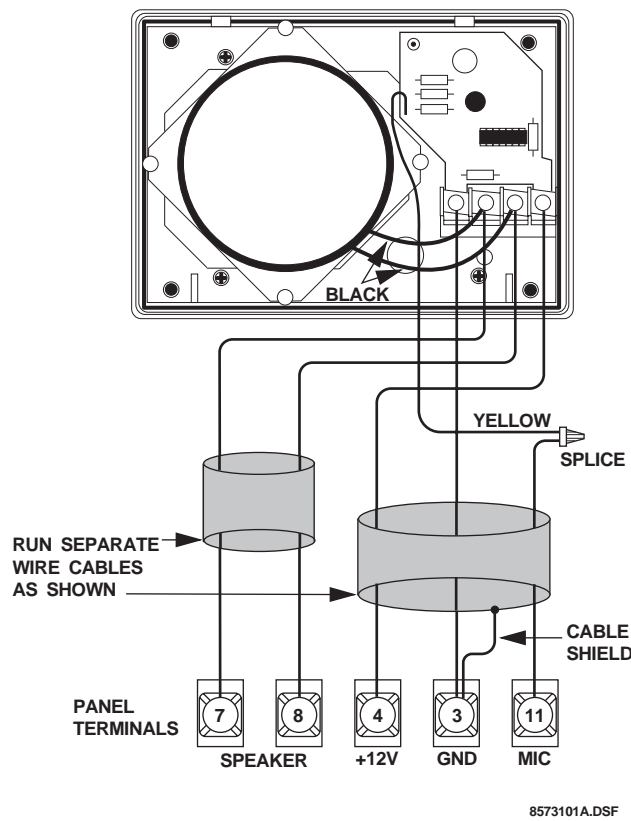
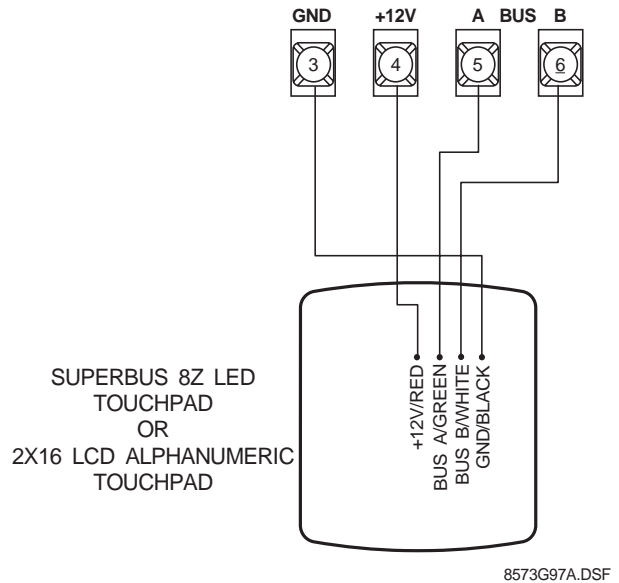

Figure 14. Connecting an Interrogator 200 to the Panel (Partition 1 use only)

## Connecting Alphanumeric and LED Touchpads

Alphanumeric and LED touchpads use the same color-coded wire scheme. Connect the touchpads to the panel power output and bus terminals as shown in Figure 15.



8573G97A.DSF

Figure 15. Connecting Alphanumeric and LED Touchpads to the Panel

## Installing SuperBus Modules

SuperBus modules can be installed inside the panel cabinet or away from the panel. Use the following guidelines when installing modules inside the panel cabinet:

- Up to 16 bus modules can be connected to the panel.

### Caution

Installing 16 bus modules of the same type (except for alphanumeric touchpads) will prevent you from accessing installer/dealer programming mode.

- Up to 3 modules can be mounted inside the cabinet.
- The panel includes two support standoffs you install to secure module backplates to the panel (see Figure 16).

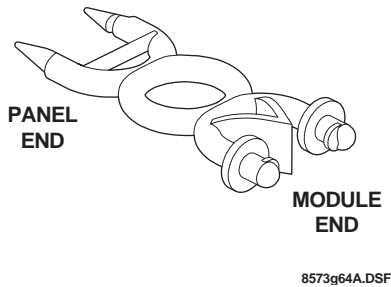
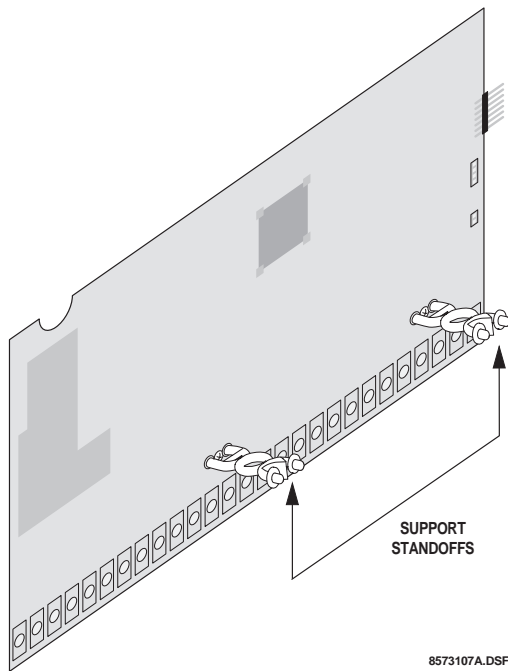

**Figure 16. Support Standoff**

- Install the standoffs at the locations shown in Figure 17.

**Note**

Even if you don't plan to mount modules inside the cabinet, install them for future use and to avoid losing them.



**Figure 17. Installing the Support Standoffs**

- The cabinet has built-in mounting clips on the top and sides that module backplates slide onto for mounting (see Figure 18).
- One SuperBus RF Receiver can be installed inside the cabinet, but it must be mounted on the right-hand side to accommodate the antennas (see Figure 18). Additional receivers must be installed outside the cabinet.

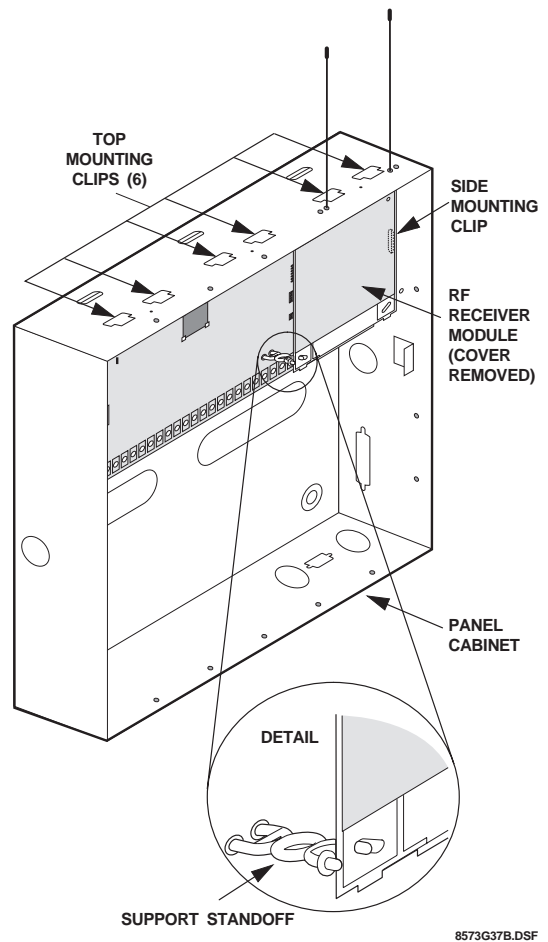

**Figure 18. Mounting SuperBus Modules Inside the Cabinet (RF Receiver Shown)**

## SuperBus RF Receiver (60-764-95R)

Connect the receiver to the panel as shown in Figure 19.

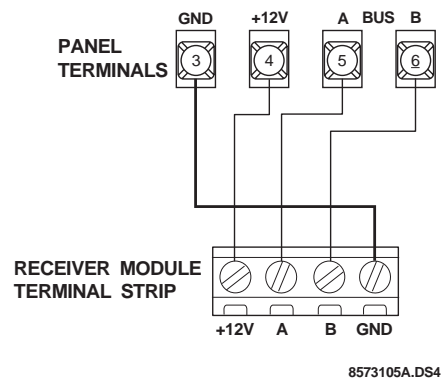
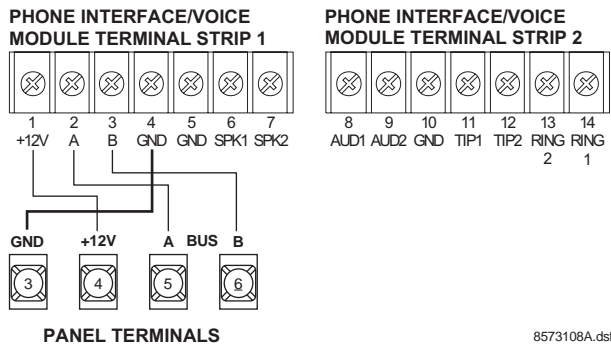

**Figure 19. Connecting the SuperBus RF Receiver to the Panel Terminals**

# Phone Interface/Voice Module (60-777)

The Phone Interface/Voice module requires panel power and bus connections, phone line connection through panel terminals and DB-8 cord (from an RJ-31X jack), and speaker connection through panel terminals.

Connect the module to the panel power and bus terminals as shown in Figure 20.



**Figure 20. Connecting the Phone Interface/Voice Module to the Panel Power and Bus Terminals**

Connect the phone line to the module through the panel terminals and DB-8 cord (from an RJ-31X jack) as shown in Figure 21.

**Note**  
For RJ-31X connections, see “Installing an RJ-31X Jack,” later in this section.

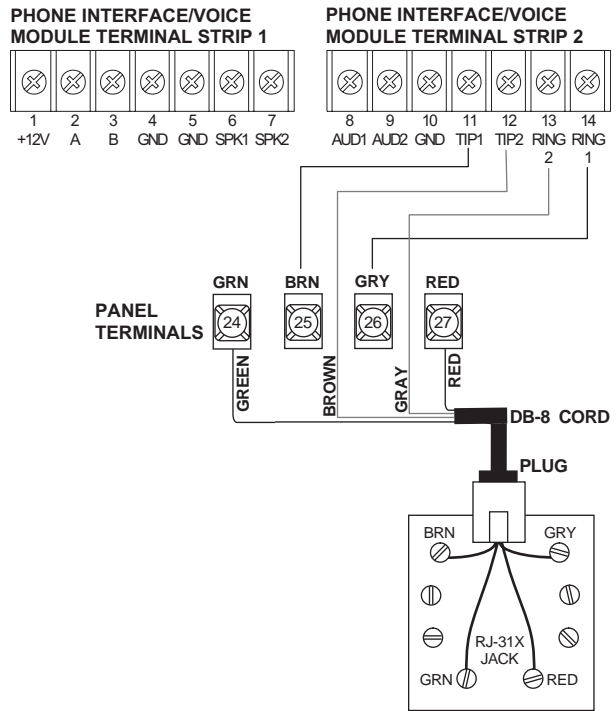

8573109A.dsf

**Figure 21. Connecting a Phone Line to the Module**

Connect an interior speaker to the Phone Interface/Voice module terminals as shown in Figure 22. When connected as shown, the speaker produces both status voice messages and alarm sounds.

**Note**  
To prevent status voice messages from being broadcast outside, do not connect exterior speakers to Phone Interface/Voice module terminals 8 and 9.

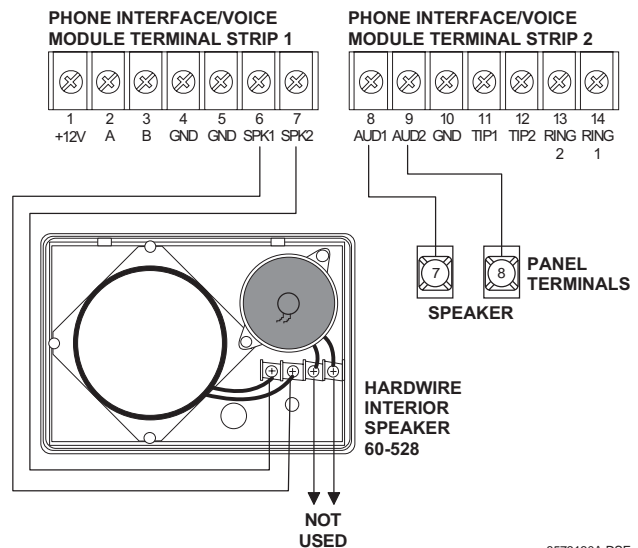

8573130A.DSF

**Figure 22. Connecting an Interior Speaker to the Phone Interface/Voice Module**



## Energy Saver Module (60-620)

Connect the Energy Saver Module to the panel and premises thermostat as shown in Figure 23.

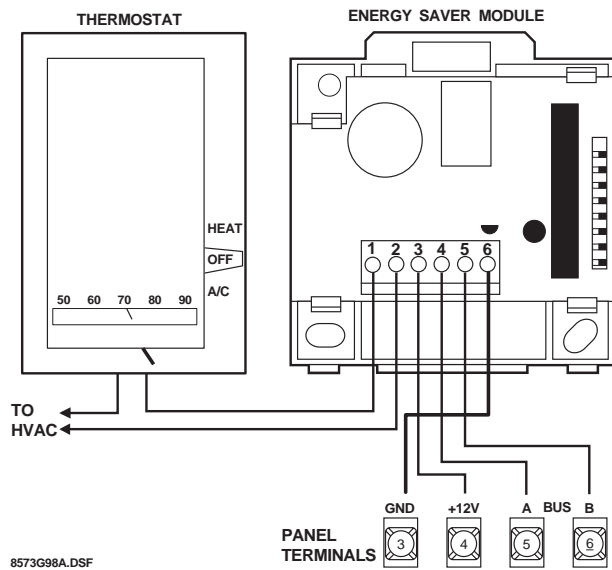

**Figure 23. Connecting the Energy Saver Module to the Panel Terminals and Premises Thermostat**

## Hardwire Input Module (60-584)

Connect the SuperBus Hardwire Input Module to the panel and detection loops as shown in Figure 24.

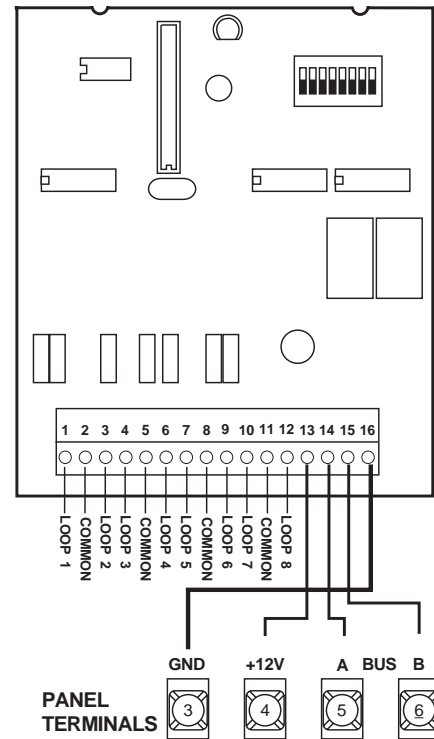

**Figure 24. Connecting the Hardwire Input Module to the Panel Terminals**

Connect all necessary input wiring using the *installation instructions* included with module.

## Hardwire Output Module (60-585)

Connect the SuperBus Hardwire Output Module to the panel as shown in Figure 25.

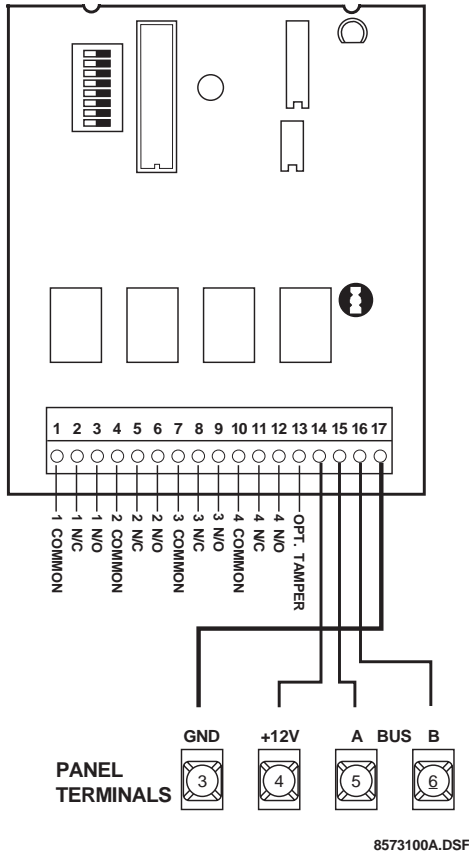

Figure 25. Connecting the Hardwire Output Module to the Panel Terminals

Connect all necessary output wiring using the *installation instructions* included with the module.

## Setting Device Address DIP Switches on Bus Devices

For correct communication and operation with the panel, all bus devices must be set with a different device address. The following bus devices use DIP switches for setting the address:

**Note**

Alphanumeric touchpads do not have DIP switches and get device addresses set later, after the panel is powered up.

- SuperBus LED Touchpad
- SuperBus RF Receiver
- SuperBus Hardwire Input Module (HIM)
- SuperBus Hardwire Output Module (HOM)
- SuperBus Phone Interface/Voice Module

Use the following guidelines when setting device address DIP switches:

- Set DIP switches *before* applying power.
- Each device connected to the bus must be assigned a unique (different) device address from 0-15 (0-7 for Hardwire Output Modules).
- Hardwire Output modules have eight DIP switches, of which only 6 through 8 are used to set the address (see Figure 26).
- Hardwire Input Modules and Phone Interface/Voice modules have eight DIP switches, of which only 5 thru 8 are used to set the address (see Figure 26).
- RF Receivers have four DIP switches.
- LED Touchpads have just 2 DIP switches and can be set for addresses 0-3 (factory set to 3).
- Alphanumeric touchpad addresses (factory set to 1) are changed in software.
- Bus devices with identical (conflicting) device addresses will not function correctly.
- All bus modules with DIP switches (except LED touchpads) are shipped from the factory set to 0. For installations where only one of these devices is installed in addition to one alphanumeric or LED touchpad, the factory setting of 0 can be used.
- If more than one alphanumeric touchpad is being installed, start with just one connected to the panel. Change the touchpad’s device address after all system programming is completed, as described in the “Programming” section of this manual.

**To set the unit number on LED Touchpads and bus modules with DIP switches:**

Set the unit number DIP switches to the desired unit number as shown in Figures 26, 27, and 28. Remember, each bus device must have a different unit number setting to work correctly.

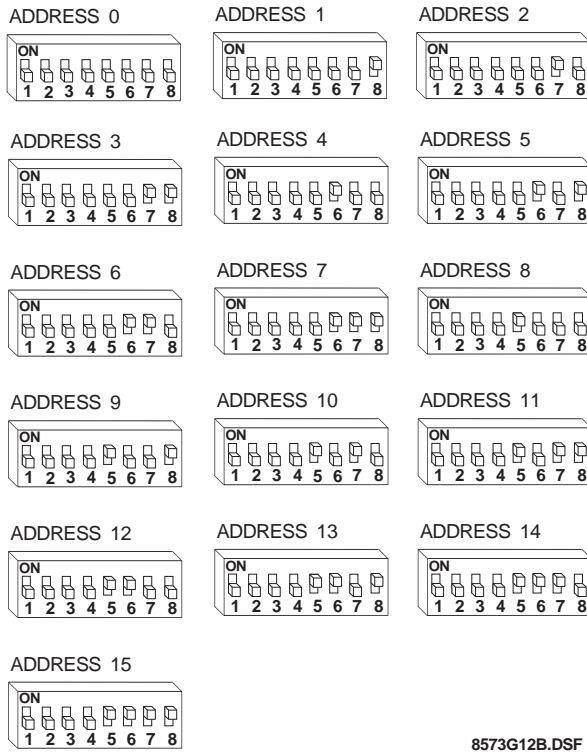

Figure 26. 8-Position DIP Switch Device Address Settings

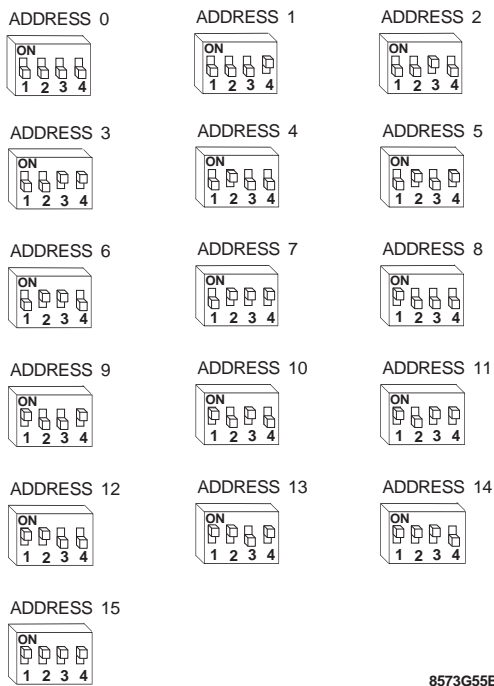

Figure 27. 4-Position DIP Switch Device Address Settings

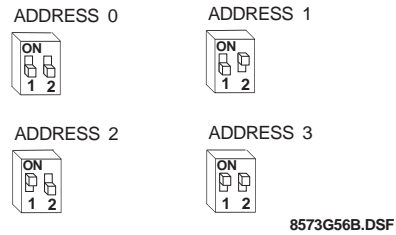

Figure 28. 2-Position DIP Switch Device Address Settings

## Installing an RJ-31X Phone Jack (13-081)

Use the following guidelines when installing an RJ-31X phone jack for system control by phone and central station monitoring.

- Locate the RJ-31X jack (CA-38A in Canada) no further than five feet from the panel.
- The panel must be connected to a standard analog (loop-start) phone line, that provides 48 volts DC (on-hook or idle) which increases to 89 to 105 volts DC (ring voltage).

### Note

The panel cannot be used on a digital or PBX phone line. These systems are designed for digital type devices only, operating anywhere from 5 volts DC and up. The panel uses an analog modem and does not have a digital converter, adapter, or interface to operate through such systems.

- For full line seizure, install an RJ-31X phone jack on the premises phone line so the panel is ahead of all phones and other devices on the line. This allows the panel to take control of the phone line when an alarm occurs, even if the phone is in use or off-hook.
- If an analog line is not available, contact your customers' telecommunications specialist and tell him/her you need an analog line off the phone switch (PBX mainframe) or a 1FB (standard business line).

### Note

Connecting the panel to an analog line off the phone switch places the panel *ahead* of the phone system, preventing panel access from phones on the premises. However, the panel can still be accessed from off-site phones.

**To connect a phone line to the panel using an RJ-31X/CA-38A jack:**

1. Run a 4-conductor cable from the TELCO protector block to the jack location (see **A** in Figure 29).
2. Connect one end of the cable to the jack (see **B** in Figure 29).
3. At the TELCO protector block, remove the premises phone lines (lines from phone jacks on premises) from the block and splice them to the black and white (or yellow) wires of the 4-conductor cable (see **C** in Figure 29).
4. Connect the green and red wires from the 4-conductor cable to the TIP (+) and RING (-) posts on the block (see **D** in Figure 29).

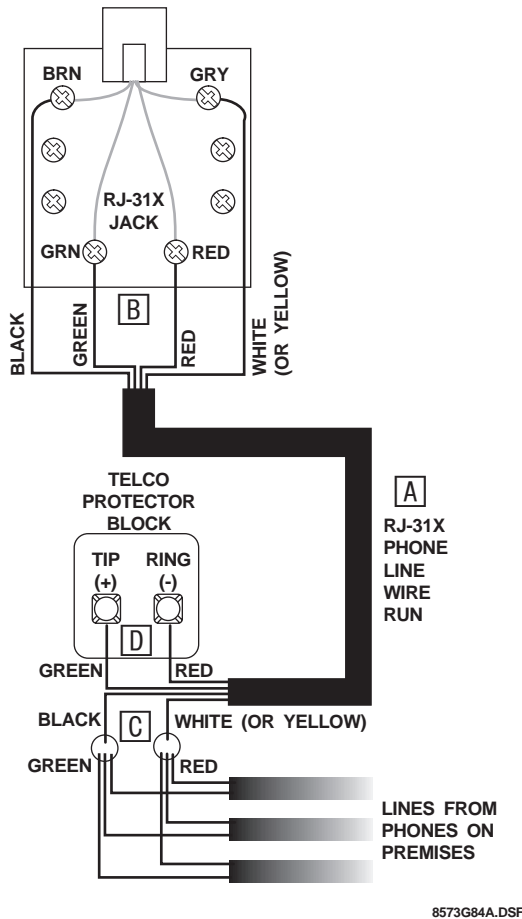

**Figure 29. Installing an RJ-31X Phone Jack**

5. Check the phones on the premises for dial tone and the ability to dial out and make phone calls. If phones do not work correctly, check all wiring and correct where necessary. Proceed to the “Troubleshooting” section of this manual if problems persist.

## Connecting the Phone Line to the Panel with a DB-8 Cord

After installing the RJ-31X jack, you are ready to connect the phone line to the panel. A DB-8 cord (included with panel) uses a plug at one end for connecting to the RJ-31X module and flying leads on the other end for panel terminal connections.

**To connect the DB-8 cord to the panel terminals and RJ-31X jack:**

1. Connect the green, brown, gray, and red flying leads from the DB-8 cord to panel terminals 24, 25, 26, and 27 (see Figure 30).
2. Insert the DB-8 cord’s plug into the RJ-31X (see Figure 30).

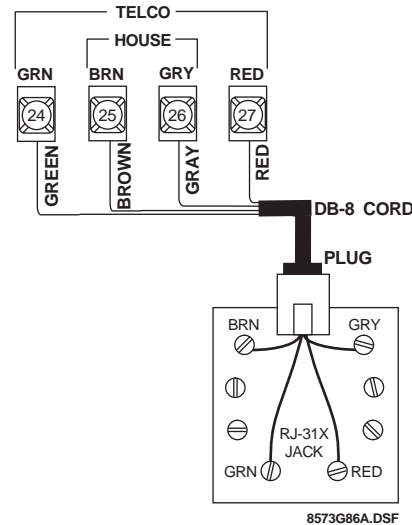

**Figure 30. Connecting the DB-8 Cord to the Panel and RJ-31X Jack**

3. Check the phones on the premises for dial tone and the ability to dial out and make phone calls. If phones do not work correctly, check all wiring and correct where necessary. Proceed to the “Troubleshooting” section of this manual if problems persist.

## Connecting the AC Power Transformer

The panel must be powered by a plug-in stepdown transformer that supplies 24 VAC, 30 VA (60-761).

For systems that include a Power Line Carrier card, Supervised Wireless Sirens, and X-10 Lamp Modules, the panel must be powered with the Line Carrier Power Transformer that supplies 24 VAC, 30 VA (60-762).

Connect the power transformer to the panel as shown in Figure 31.

### Caution

Do not plug in the power transformer at this time. The panel must be powered up using the sequence of steps described in the following section, "Power Up the Panel."

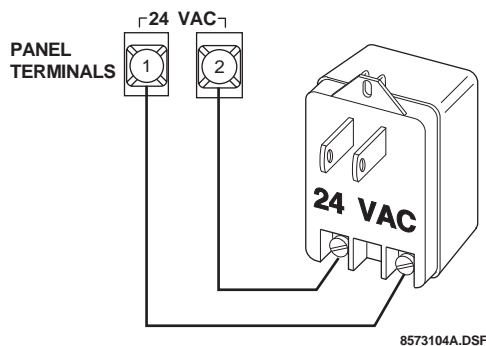

Figure 31. Connecting a Power Transformer to the Panel Terminals

## Power Up the Panel

After connecting and wiring all devices to the panel and setting all unit number DIP switches on bus devices, you are ready to apply AC and backup battery power to the panel.

### Note

Before applying power to the panel, check the DIP switch setting on all bus devices to make sure each one is set to a different unit number (device address) setting.

### To power up the panel:

1. Connect the red and black battery leads (included with panel) to the lugs located in the upper-left area of the panel circuit board (see Figure 32).

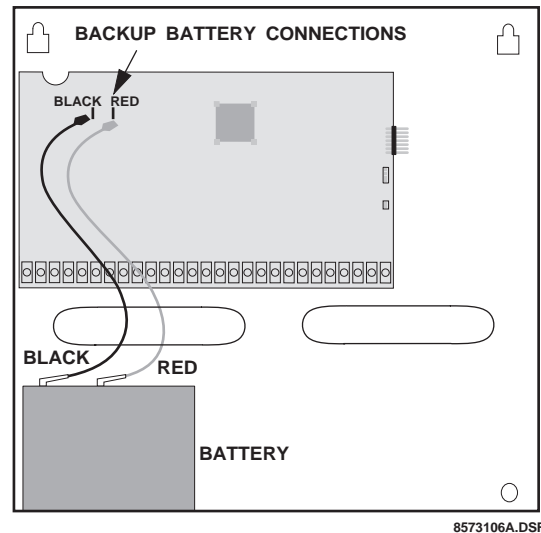

Figure 32. Connecting the Backup Battery to the Panel

2. Connect the other ends of the battery leads to the battery terminals.
3. Plug the transformer into an outlet that is not controlled by a switch.

Alphanumeric touchpads display **\*\*\*\*\***, then a date and time display.

### Note

If alphanumeric touchpads don't display anything, immediately unplug the transformer and disconnect the backup battery. Refer to the "Troubleshooting" section.

4. To permanently mount the transformer, unplug it and remove the existing screw securing the AC outlet cover.

### WARNING!

**Use extreme caution when securing the transformer to a metal outlet cover. You could receive a serious shock if a metal outlet cover drops down onto the prongs of the plug while you are securing the transformer and cover to the outlet box.**

5. Hold the outlet cover in place and plug the transformer into the lower receptacle.
6. Use the screw supplied with the transformer to secure the transformer to the outlet cover.

## Programming the Panel

---

For on-site system programming, an alphanumeric touchpad is required. All alphanumeric touchpads should have device addresses changed (if the installation includes more than one) before entering program mode.

## Setting Alphanumeric Touchpad Device Addresses

---

The SuperBus 2x16 Alphanumeric Touchpad device address is factory set to 1 and should not need changing if only one touchpad is installed.

If the system includes more than one of these touchpads, each one must be assigned a different unit number to work correctly.

The following describes how to set alphanumeric touchpad device addresses.

### To set an alphanumeric touchpad device address:

1. At the touchpad, press and hold the **D** and **6** buttons together for at least 2 seconds. The display should show *DA n*, where *n* is the touchpad's current address (000 - 015).

#### Note

At this time, the touchpad is in configuration mode and no longer communicating to the panel. The system may immediately indicate a bus failure. Ignore the failure and continue with the procedure, which will clear after successfully changing the touchpad's unit number.

2. Press **#**. The display shows *ENTER \_*.
3. Enter the desired three digit device address (000 - 015), then press **#**. The display shows *DA n*, where *n* is the touchpad's new device address.
4. Press **\*** to exit from the configuration mode.

#### Note

If the touchpad's new unit number was previously learned by the panel, communication between the touchpad and the panel begins immediately. However, if the touchpad's new unit number has never been learned by the panel, continue with step five.

5. Force the panel to scan bus devices as follows:

- a). For systems where this is the only installed touchpad, remove panel AC and battery power, then re-apply power.
- b). For systems with more than one touchpad, go to another system touchpad and enter **[8]** + installer **[C][0][D][E]** (default = 4321) + **[0]** + **[1]**. The display shows *SCANNING BUS DEVICES*, then returns to the time and date display.

#### Note

When you change an alphanumeric touchpad device address, the panel retains the old number in memory. This may cause a bus failure message if the old address is not being used for another bus device. To clear the failure, you must enter program mode and delete the old device address from panel memory. Refer to the Accessory Modules—Bus Devices—Unit - Type menus described later in this section.

## Entering Program Mode

---

Entering program mode is done using an installer/dealer code (default = 4321). The system can be put into program mode only when the system is disarmed.

### To enter program mode:

1. Make sure the system is disarmed.
2. Press **[8]** + **[4][3][2][1]** + **[0]** + **[0]**. The touchpad shows *SYSTEM PROGRAMMING*.

## Touchpad Button Programming Functions

---

In program mode, touchpad buttons let you navigate to all installer programming menus for configuring the system. Table 5 describes the touchpad button functions in program mode.

**Table 5. Alphanumeric Touchpad Button Programming Functions**

Button	Programming Function
Numeric Buttons	Used to enter numeric values such as menu numbers, delay times and sensor numbers. Also used to enter text character and word codes during sensor text programming.
<b>A</b>	Scrolls backward to previous menu. Displays previous sensor text library character during sensor text programming.
<b>B</b>	Scrolls forward to next menu on current tier. Displays next sensor text library character during sensor text programming.
<b>C</b>	Used to enter pauses when programming phone numbers.
<b>D</b>	Deletes programming for certain menu items.
<b>#</b>	Used to move forward to next menu tier, and enter or accept displayed entry.
<b>*</b>	Cancels and exits displayed programming command (if pressed before #). Backs out to previous menu tier.

## Moving Through Program Mode Tiers and Menus

There are two basic tiers of programming menus. Tier 1 menus are accessible immediately after entering program mode (see Figure 33).

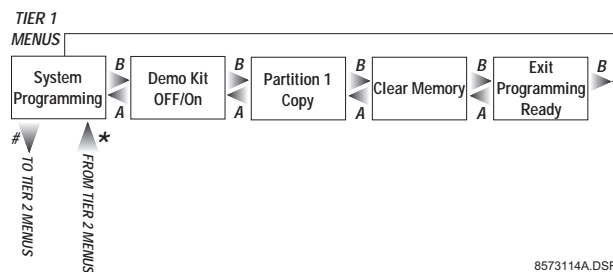

**Figure 33. Tier 1 Program Menus**

Arrows pointing right represent pressing **B** to advance forward through the menus. Pressing **A** moves through the menus in reverse.

The arrow below the *System Programming* menu represents pressing **#** to advance to tier 2 programming menus. Only when *System Programming* is displayed can you advance to tier 2 menus (see Figure 34).

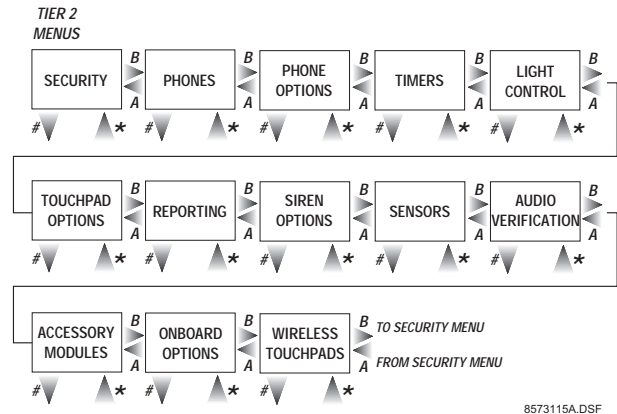

**Figure 34. Tier 2 Program Menus**

Again, arrows pointing right represent pressing **B** to advance forward through the menus. Pressing **A** moves through the menus in reverse.

Arrows below each menu represent pressing **#** to advance to those settings that pertain to that menu. Only when a specific menu is displayed can you advance to those settings. For example, from the *SENSORS* menu pressing **#** gives you access to learning sensors, programming sensor text, deleting sensors, and viewing sensor programming.

Settings in tier 2 menu can also be accessed by entering shortcut numbers. See the section, “Programming Tier 2 Menu Items” for complete details.

## Programming Tier 1 Menu Items

This section guides you through programming tier 1 menu items as they appear in sequence. Depending on whether you’re installing a new system or changing programming to an existing system will determine the exact order you need to follow. For example, for new installations you should always clear memory before programming any system settings.



<b>Demo Kit Mode</b>	<i>(Reporting—Global)</i>
<p>(Default = off) This setting determines whether the panel is used for a standard installation (off) or as a demo kit (on). When on, all system settings are set to demo kit default settings after a memory clear.</p> <p><b>To turn Demo Kit Mode off or on:</b></p> <p>With the display showing <i>DEMO KIT MODE OFF/ON</i> (current setting), press <b>1</b> (off) or <b>2</b> (on), then press #.</p> <p>The display flashes the entered setting, then stops after pressing # and displays <i>DEMO KIT MODE OFF/ON</i> (new setting).</p>	
<b>Partition 1 Copy</b>	<i>(System Programming)</i>
<p>(Default = none) After programming all settings pertaining to partition 1, you can make an exact copy to use for partition 2. This helps reduce programming time when the system is set up for two partitions. If there are certain settings that are unique to partition 2, simply advance to the appropriate menu and make the necessary changes.</p> <p><b>To Copy Partition 1:</b></p> <p>With the display showing <i>PARTITION 1 COPY</i>, press # + installer <b>CODE</b> (default = 4321) + #.</p> <p>The display flashes, then stops after pressing # and shows <i>PARTITION 1 COPY DONE</i>.</p>	
<b>Clear Memory</b>	<i>(System Programming)</i>
<p>Clearing memory deletes all existing programming information (except the Dealer Code). Clear memory on all newly installed panels before programming.</p> <p><b>To Clear Panel Memory:</b></p> <ol style="list-style-type: none"> <li>With the system in program mode, press <b>B</b> until the display shows <i>CLEAR MEMORY</i>.</li> <li>Press # and the display shows <i>ENTER CODE TO CLEAR MEMORY</i>.</li> <li>Enter the <b>4-digit installer CODE</b> (default = 4321) or <b>dealer CODE</b> (if programmed) + #.</li> </ol> <p>After about five seconds, the system restarts and the panel scans the bus to learn all bus device unit numbers.</p> <p>If the system doesn't respond as described, repeat step 3.</p>	

## Programming Tier 2 Menu Items

This section guides you through programming tier 2 menu items as they appear in sequence. Figure 35 shows the menus available on tier 2.

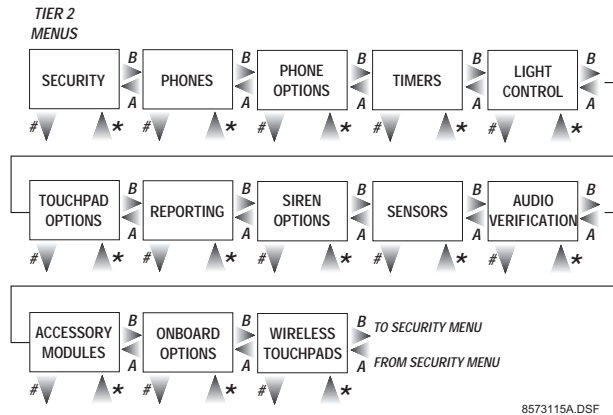

Figure 35. Tier 2 Program Menus

Each menu on tier 2 represents a group of settings related to the menu name. Some tier 2 menus break down into settings that affect the whole system (global) or a specific partition.

## Using Shortcut Numbers

To go directly to a setting in tier 2, you can enter the shortcut number for that setting. Shortcut numbers in this manual appear in parenthesis (), under the setting name. For example:

<b>Downloader Code</b>	<i>Security-Global)</i>
<b>(0000)</b>	

Shortcut numbers can be used from any setting location within tier 2.

### To advance to tier 2 program menus:

With the system in program mode and the display showing *SYSTEM PROGRAMMING*, press **#** once. The display should show *SECURITY*.



# Security Menu

The *SECURITY* menu lets you choose whether security settings affect the whole system (global) or a specific partition.

**To access global or partition security menu items:**

1. With the display showing *SECURITY*, press **#**.  
The display should show *GLOBAL*.
2. Press **#** again to advance to global settings  
or--Press **A** or **B** to display *PARTITION n*, then  
press **#** to advance to partition 1 or 2 settings.

The following describes how to program the security settings that appear under *GLOBAL*.

<b>Downloader Code (0000)</b>	<i>Security-Global)</i>
<p>(Default = 12345) The 5-digit downloader code is used in conjunction with downloader programming. The downloader operator must have the panel's account number and downloader code in order to perform any programming.</p>	
<p><b>To program a Downloader Code:</b></p> <p>With the display showing <i>DOWNLOADER CODE nnnnn</i> (<i>current code</i>), enter the desired <b>5-digit code</b>, + #. The display flashes the entered code, then stops after pressing # and displays <i>DOWNLOADER CODE nnnnn</i> (<i>new code</i>).</p>	
<p><b>Note</b> The Downloader Code cannot be deleted or cleared from panel memory. To change the Downloader Code to its default setting, enter 12345 in the procedure above.</p>	

<b>Installer Code (0001)</b>	<i>(Security-Global)</i>
<p>(Default = 4321) The 4-digit installer code is used for entering program mode and changing system settings. If a dealer code (see below) is programmed, only those settings not associated with phone numbers can be changed.</p>	
<p><b>To program an Installer Code:</b></p> <p>With the display showing <i>INSTALLER CODE nnnn</i> (<i>current code</i>), enter the desired <b>4-digit code</b> + #. The display flashes the entered code, then stops after pressing # and displays <i>INSTALLER CODE nnnn</i> (<i>new code</i>).</p>	
<p><b>Note</b> The Installer Code cannot be deleted or cleared from panel memory. To change the Installer Code to its default setting, enter 4321 in the procedure above.</p>	
<b>Dealer Code (0002)</b>	<i>(Security-Global)</i>
<p>(Default = none) The 4-digit dealer code is used to prevent unauthorized persons from changing the programmed central station phone number. When changed from its default setting, all central station phone numbers can be changed only by entering program mode using the dealer code. (If a Dealer Code is programmed, entering program mode with the installer code lets you program all system settings except for the Dealer Code and central station phone numbers.)</p>	
<p><b>To program a Dealer Code:</b></p> <p>With the display showing <i>DEALER CODE ****</i>, enter the desired <b>4-digit code</b> + #. The display flashes the entered code, then stops after pressing # and displays <i>DEALER CODE nnnn</i> (<i>new code</i>).</p>	
<p><b>To delete a Dealer Code:</b></p> <p>With the display showing <i>DEALER CODE nnnn</i> (<i>current code</i>), press <b>D</b>. The display shows <i>DEALER CODE ****</i>.</p>	
<p><b>Note</b> The Dealer Code cannot be deleted by clearing panel memory. If you don't remember your Dealer Code, call Technical Services for assistance.</p>	

## Programming the Panel

The following describes how to program the security settings that appear under PARTITION 1 and 2.

<b>Account Number</b> (Security—Partition 1, 2) (0010—partition 1, 0020—partition 2)
(Default = 00000) The account number is used as panel (or customer) identification for the central monitoring station. The panel sends the account number every time it reports to the central station. Account numbers must be 1 to 10 digits long.
<b>To program an Account Number:</b>
<ol style="list-style-type: none"><li>1. With the desired partition selected, press <b>B</b> until the display shows <i>ACCOUNT NUMBER nnnnn</i>.</li><li>2. Enter the desired account number, then press <b>#</b>. The display flashes the entered number, then stops after pressing <b>#</b> and displays <i>ACCOUNT NUMBER nnnnn (new account number)</i>.</li></ol>
<b>Quick Arm</b> (Security—Partition 1, 2) (0011—partition 1, 0021—partition 2)
(Default = off) Quick Arm allows system arming without using an access code. When turned on, the system arming level can be increased from Level 1-OFF to LEVEL 2-STAY, from Level 1-OFF to LEVEL 3-AWAY, or from Level 2-STAY to LEVEL 3-AWAY without entering an access code.
A valid access code is still required to decrease the arming level or disarm the system.
<b>To turn Quick Arm off or on:</b>
<ol style="list-style-type: none"><li>1. With the desired partition selected, press <b>B</b> until the display shows <i>QUICK ARM OFF/ON (current setting)</i>.</li><li>2. Press <b>1</b> (off) or <b>2</b> (on), then press <b>#</b>. The display flashes the entered setting, then stops after pressing <b>#</b> and displays <i>QUICK ARM OFF/ON (new setting)</i>.</li></ol>

<b>Keyswitch Arming</b> (Security—Partition 1) (0012—partition 1, 0022—partition 2)
(Default = off) Keyswitch arming allows partition 1 arming using a wired keyswitch connected to a hardware zone (loop) input or a wireless door/window sensor, learned as zone/sensor number 01.
<b>To turn Keyswitch Arming off or on:</b>
<ol style="list-style-type: none"><li>1. With partition 1 selected, press <b>B</b> until the display shows <i>KEYSWITCH ARMING OFF/ON (current setting)</i>.</li><li>2. Press <b>1</b> (off) or <b>2</b> (on), then press <b>#</b>. The display flashes the entered setting, then stops after pressing <b>#</b> and displays <i>KEYSWITCH ARMING OFF/ON (new setting)</i>.</li></ol>
<b>Duress Code</b> (Security—Partition 1, 2) (0013—partition 1, 0023—partition 2)
(Default = none) The duress code is a unique 4-digit access code that allows users to operate the system and, at the same time, instructs the panel to send a silent alarm report to the central station. Each partition can be programmed with a different duress code.
<b>Caution</b> Because using duress codes often results in false alarms due to code entry errors, it is strongly recommended not to program duress codes.
If a duress code is absolutely necessary, their use with an Interrogator 200 is highly recommended to reduce false alarms and accidental dispatches.
<b>To program a Duress Code:</b>
<ol style="list-style-type: none"><li>1. With the desired partition selected, press <b>B</b> until the display shows <i>DURESS CODE ****</i>.</li><li>2. Enter the desired 4-digit duress code, then press <b>#</b>. The display flashes the entered setting, then stops after pressing <b>#</b> and displays <i>DURESS CODE nnnn (new code)</i>.</li></ol>
<b>To delete a Duress Code:</b>
<ol style="list-style-type: none"><li>1. With the desired partition selected, press <b>B</b> until the display shows <i>DURESS CODE nnnn (current code)</i>.</li><li>2. Press <b>D</b>. The display shows <i>DURESS CODE ****</i>.</li></ol>

## Phones Menu

The *PHONES* menu lets you set up central station reporting for the system (global) and pager reports (partition specific).

The following describes how to program the settings that appear under *CS PHONE 1-3*.

### Phone Number *(Phones—CS Phone 1-3)* (0100-cs phone 1, 0110-cs phone 2, 0120-cs phone 3)

(Default = none) This setting is used for programming the central station receiver's phone number. Phone numbers can be 1 to 24 digits long, including pauses. To enter pauses, press **C**.

#### Note

The PHONE NUMBER menus are not accessible if a Dealer Code is programmed and the Installer Code is used to enter installer programming mode. To access these menus when a Dealer Code is programmed, you must enter installer programming mode using the Dealer Code.

#### Note

Phone numbers that disable call-waiting (\*70) must be programmed using ITI ToolBox.

#### To program a Central Station Phone Number:

With the display showing *PHONE NUMBER \_* (or *current number*), enter the desired phone number + #.

The display flashes the entered number, then stops after pressing # and displays *PHONE NUMBER* (new number).

#### To delete a Central Station Phone Number:

With the display showing *PHONE NUMBER* (current number), press **D**.

The display shows *PHONE NUMBER \_*.

### High Level Rpts *(Phones—CS Phone 1-3)* (0101-cs phone 1, 0111-cs phone 2, 0121-cs phone 3)

(Defaults: CS Phone 1 = on, CS Phone 2 = off, CS Phone 3 = off) This setting determines whether the following conditions report to the central station:

Fire, Police, Auxiliary, Duress, and Freeze alarms, No Activity, Receiver Failure (or jam), and System Tamper (40 incorrect keypresses or touchpad supervisory).

#### To turn High-Level Reports off or on:

With the display showing *HIGH LEVEL RPTS OFF/ON* (current setting), press **1** (off) or **2** (on), then press #.

The display flashes the entered setting, then stops after pressing # and displays *HIGH LEVEL RPTS OFF/ON* (new setting).

### Low Level Rpts *(Phones—CS Phone 1-3)* (0102-cs phone 1, 0112-cs phone 2, 0122-cs phone 3)

(Defaults: CS Phone 1 = on, CS Phone 2 = off, CS Phone 3 = off) This setting determines whether the following conditions report to the central station:

Force Armed, Hardwire Zone Trouble (open or short), Supervisory (wireless sensors), Low Battery (wireless sensors and touchpads).

#### To turn Low-Level Reports off or on:

With the display showing *LOW LEVEL RPTS OFF/ON* (current setting), press **1** (off) or **2** (on), then press #.

The display flashes the entered setting, then stops after pressing # and displays *LOW LEVEL RPTS OFF/ON* (new setting).

### Exception Rpts *(Phones—CS Phone 1-3)* (0103-cs phone 1, 0113-cs phone 2, 0123-cs phone 3)

(Defaults: all off) This setting determines whether the panel reports to the central station if the system is not armed or disarmed at the specified schedule times, if open/close reports are turned on.

#### To turn Exception Reports off or on:

With the display showing *EXCEPTION RPTS OFF/ON* (current setting), press **1** (off) or **2** (on), then press #.

The display flashes the entered setting, then stops after pressing # and displays *EXCEPTION RPTS OFF/ON* (new setting).

### Open/Close Rpts *(Phones—CS Phone 1-3)* (0104-cs phone 1, 0114-cs phone 2, 0124-cs phone 3)

(Defaults: all off) This setting determines whether opening and closing reports are sent to the central station. When turned on, the panel sends a closing report when the system is armed and an opening report when the system is disarmed.

#### Note

To use this feature, the *OPENING REPORTS* and *CLOSING REPORTS* settings under the *REPORTING* menu must be turned on for that partition.

#### To turn Opening/Closing Reports off or on:

With the display showing *OPEN/CLOSE RPTS OFF/ON* (*current setting*), press **1** (off) or **2** (on), then press #.

The display flashes the entered setting, then stops after pressing # and displays *OPEN/CLOSE RPTS OFF/ON* (*new setting*).

### Backup *(Phones—CS Phone 1-3)* (0105-cs phone 1, 0115-cs phone 2, 0125-cs phone 3)

(Defaults: CS Phone 1 = on, CS Phone 2 = off, CS Phone 3 = off) This setting determines whether the panel uses another programmed central station phone number for reporting if three initial attempts are unsuccessful. CS PHONE 1 is backed up by CS PHONE 2, and CS PHONE 2 and 3 are backed up by CS PHONE 1. The panel makes up to 16 attempts (8 per phone number), alternating between the two programmed phone numbers.

For example, if *BACKUP* is on and three failed reporting attempts occur using CS PHONE 1, the panel switches to CS PHONE 2 for three more reporting attempts. If these attempts fail, the panel switches back to CS PHONE 1 for five more reporting attempts and, if necessary, switches back to CS PHONE 2 for five final attempts.

#### To turn Backup off or on:

With the display showing *BACKUP OFF/ON* (*current setting*), press **1** (off) or **2** (on), then press #. The display flashes the entered setting, then stops after pressing # and displays *BACKUP OFF/ON* (*new setting*).

### SIA/CID Reporting *(Phones—CS Phone 1-3)* (0106-cs phone 1, 0116-cs phone 2, 0126-cs phone 3)

(Defaults: all CID) This setting determines whether the panel uses the SIA or CID (Contact ID) reporting format for central station communication.

#### To select SIA or CID reporting:

With the display showing *REPORTING FORMAT SIA/CID* (*current setting*), press **1** (for SIA) or **2** (for CID), then press #.

The display flashes the entered setting, then stops after pressing # and displays *REPORTING FORMAT SIA/CID* (*new setting*).

The following describes how to program the phone settings that appear under *PAGER PHONE 1* thru *5*.

### Phone Number *(Phones—Pager Phone 1-5)* (0130-pager 1, 0140-pager 2, 0150-pager 3, 0160-pager 4, 0170-pager 5)

(Default = none) This setting is used for programming a phone number that communicates to a pager. Phone numbers can be 1 to 24 digits long and include pauses, call-waiting disable (\*70), skylink number, and 7-digit PIN number.

#### Note

Phone numbers that disable call-waiting (\*70) must be programmed using ITI ToolBox.

#### To program a Pager Phone Number:

With the display showing *PHONE NUMBER \_* (*or current number*), enter the desired pager phone number including pauses (press **C** for 3-second pause), then press #.

The display flashes the entered number, then stops after pressing # and displays *PHONE NUMBER* (*new number*).

#### To delete a Pager Phone Number:

With the display showing *PHONE NUMBER* (*current number*), press **D**.

The display shows *PHONE NUMBER \_*.

**High Level Rpts** (Phones—Pager Phone 1-5)  
(0131-pager 1, 0141-pager 2, 0151-pager 3,  
0161-pager 4, 0171-pager 5)

(Default = on) This setting determines whether the following alarm conditions report to a pager:

Fire, Police, Auxiliary, Duress, and Freeze alarms, No Activity, Receiver Failure (or jam), and System Tamper (40 incorrect keypresses or touchpad supervisory).

**To turn High-Level Reports off or on:**

With the display showing *HIGH LEVEL RPTS OFF/ON* (current setting), press **1** (off) or **2** (on), then press #.

The display flashes the entered setting, then stops after pressing # and displays *HIGH LEVEL RPTS OFF/ON* (new setting).

**Low Level Rpts** (Phones—Pager Phone 1-5)  
(0132-pager 1, 0142-pager 2, 0152-pager 3,  
0162-pager 4, 0172-pager 5)

(Default = off) This setting determines whether the following non-alarm conditions report to a pager:

Force Armed, Hardwire Zone Trouble (open or short), Supervisory (wireless sensors), Low Battery (wireless sensors and touchpads).

**To turn Low-Level Reports off or on:**

With the display showing *LOW LEVEL RPTS OFF/ON* (current setting), press **1** (off) or **2** (on), then press #.

The display flashes the entered setting, then stops after pressing # and displays *LOW LEVEL RPTS OFF/ON* (new setting).

**Exception Rpts** (Phones—Pager Phone 1-5)  
(0133-pager 1, 0143-pager 2, 0153-pager 3,  
0163-pager 4, 0173-pager 5)

(Default = off) This setting determines whether the panel reports to a pager if the system is not armed or disarmed at the specified schedule times, if open/close reports are turned on.

**To turn Exception Reports off or on:**

With the display showing *EXCEPTION RPTS OFF/ON* (current setting), press **1** (off) or **2** (on), then press #.

The display flashes the entered setting, then stops after pressing # and displays *EXCEPTION RPTS OFF/ON* (new setting).

**Open/Close Rpts** (Phones—Pager Phone 1-5)  
(0134-pager 1, 0144-pager 2, 0154-pager 3,  
0164-pager 4, 0174-pager 5)

(Default = off) This setting determines whether opening and closing reports are sent to a pager. When turned on, the panel sends a closing report when the system is armed and an opening report when the system is disarmed.

**Note**

To use this feature, the *OPENING REPORTS* and *CLOSING REPORTS* settings under the *REPORTING* menu must be turned on for that partition.

**To turn Opening/Closing Reports off or on:**

With the display showing *OPEN/CLOSE RPTS OFF/ON* (current setting), press **1** (off) or **2** (on), then press #.

The display flashes the entered setting, then stops after pressing # and displays *OPEN/CLOSE RPTS OFF/ON* (current setting).

**Latchkey Reports** (Phones—Pager Phone 1-5)  
(0135-pager 1, 0145-pager 2, 0155-pager 3,  
0165-pager 4, 0175-pager 5)

(Default = on) This setting determines whether the panel reports to a pager when the system is armed or disarmed, according to latchkey time scheduling.

**To turn Latchkey reports off or on:**

With the display showing *LATCHKEY REPORTS OFF/ON* (current setting), press **1** (off) or **2** (on), then press #.

The display flashes the entered setting, then stops after pressing # and displays *LATCHKEY REPORTS OFF/ON* (new setting).

**Streamlining** (Phones—Pager Phone 1-5)  
(0136-pager 1, 0146-pager 2, 0156-pager 3,  
0166-pager 4, 0176-pager 5)

(Default = on) This setting determines whether the panel includes (off) or excludes (on) the account number when reporting to a pager.

**To turn Streamlining off or on:**

With the display showing *STREAMLINING OFF/ON* (current setting), press **1** (off) or **2** (on), then press #.

The display flashes the entered setting, then stops after pressing # and displays *STREAMLINING OFF/ON* (new setting).

## Programming the Panel

### Ptn Assignment *(Phones—Pager Phone 1-5)* (0137-pager 1, 0147-pager 2, 0157-pager 3, 0167-pager 4, 0177-pager 5)

(Default = 1) This setting determines the partition that reports to a pager. Both partitions can be assigned to report to a single pager.

#### To set up Partition Assignments for pager reporting:

With the display showing *PTN ASSIGNMENT 1/2/12 (current setting)*, press **1** or **2** to select partition 1 or 2 or press **1 and 2** to select both, then press **#**. The display flashes the entered setting, then stops after pressing **#** and displays *PTN ASSIGNMENT 1/2/12 (new setting)*.

The following describes how to program the phone settings that appear under *DOWNLOADER PHONE*.

### Phone Number *(Downloader Phone)* (0180)

(Default = none) This setting is used for programming the phone number of a computer used for programming the panel from off-site. Phone numbers can be 1 to 24 digits long, including pauses. To enter pauses, press **C**.

#### To program a downloader phone number:

With the display showing *PHONE NUMBER (current number)*, enter the desired phone number + **#**. The display flashes the entered number, then stops after pressing **#** and displays *PHONE NUMBER (new number)*.

## Phone Options Menu

The *PHONE OPTIONS* menu lets you set up system phone access and communications that affect the whole system (global) or a specific partition.

The following describes how to program the phone option settings that appear under *GLOBAL*.

### Phone Test *(Phone Options—Global)* (0200)

(Default = on) This setting determines if the user can, at any time, test the communication from the panel to the central station or a pager by entering 8 + CODE + 2 (# + 8 + CODE + 2 from a touch-tone phone).

#### To turn the Phone Test setting off or on:

With the display showing *PHONE TEST OFF/ON (current setting)*, press **1** (off) or **2** (on), then press **#**. The display flashes the entered setting, then stops after pressing **#** and displays *PHONE TEST OFF/ON (new setting)*.

### Auto Phone Test *(Phone Options—Global)* (0201)

(Default = off) This setting determines if the panel sends a phone test automatically to the central station or a pager on a predetermined schedule. (Refer to the “Phone Test Freq.” and “Next Phone Test” settings found under *TIMERS—GLOBAL*).

#### To turn Automatic Phone Test off or on:

With the display showing *AUTO PHONE TEST OFF/ON (current setting)*, press **1** (off) or **2** (on), then press **#**. The display flashes the entered setting, then stops after pressing **#** and displays *AUTO PHONE TEST OFF/ON (new setting)*.

### Comm Failure *(Phone Options—Global)* (0202)

(Default = on) This setting determines whether the panel activates trouble beeps to alert users on the premises that communication to the central station failed.

#### To turn Communication Failure notification off or on:

With the display showing *COMM FAILURE OFF/ON (current setting)*, press **1** (off) or **2** (on), then press **#**. The display flashes the entered setting, then stops after pressing **#** and displays *COMM FAILURE OFF/ON (new setting)*.

**DTMF Dialing (0203)** *(Phone Options—Global)*

(Default = on) This setting determines whether the panel uses DTMF tones (on) or pulse (off) for dialing programmed phone numbers.

**To turn DTMF Dialing off or on:**

With the display showing *DTMF DIALING OFF/ON (current setting)*, press **1** (off) or **2** (on), then press #. The display flashes the entered setting, then stops after pressing # and displays *DTMF DIALING OFF/ON (new setting)*.

**Dialer Abort (0204)** *(Phone Options—Global)*

(Default = on) This setting determines whether users can stop the panel from reporting an intrusion or auxiliary alarm condition to the central station. If dialer abort is on and the user accidentally causes an alarm condition, entering the disarm command and access code within 30 seconds stops the panel from reporting the alarm, preventing a false dispatch. Fire alarm reports to the central station cannot be aborted.

**Note**

The 30-second time setting can only be changed using ITI ToolBox.

**To turn Dialer Abort off or on:**

With the display showing *DIALER ABORT OFF/ON (current setting)*, press **1** (off) or **2** (on), then press #. The display flashes the entered setting, then stops after pressing # and displays *DIALER ABORT OFF/ON (new setting)*.

**Pager Delay (0205)** *(Phone Options—Global)*

(Default = 15 seconds) This setting determines how long a report is delayed to a pager (00 - 30 seconds), after the panel dials the pager number.

**To set the Pager Delay time:**

With the display showing *PAGER DELAY nn (current setting)*, enter a two digit time (00 - 30), then press #. The display flashes the entered setting, then stops after pressing # and displays *PAGER DELAY nn (new setting)*.

option settings that appear under *PARTITION 1* and *PARTITION 2*.

**Note**

A Phone Interface/Voice module must be installed for the system to use the settings under *PHONE OPTIONS—PARTITION 1* and *PARTITION 2*.

**Remote Access (0210—partition 1, 0220—partition 2)** *(Phone Options—Partition 1, 2)*

(Default = on) This setting determines whether users can access and control the system from an off-site phone.

**To turn Remote Access off or on:**

1. With the desired partition selected, press **B** until the display shows *REMOTE ACCESS OFF/ON (current setting)*.
2. Press **1** (off) or **2** (on), then press #. The display flashes the entered setting, then stops after pressing # and displays *REMOTE ACCESS OFF/ON (new setting)*.

**Ring/Hang/Ring (0211—partition 1, 0221—partition 2)** *(Phone Options—Partition 1, 2)*

(Default = on) This setting determines how the panel picks up (seizes) the phone line for remote access. When turned on, the user calls the premises, listens for one or two full rings, hangs up, then calls the premises again within 10-40 seconds of hanging up. The system answers after the first ring. The “on” setting is recommended if an answering machine shares the phone line with the panel.

When turned off, the user calls the premises and listens for 12 full rings before the system answers. The “off” setting is recommended if there is no answering machine sharing the phone line with the panel.

**To turn Ring/Hang/Ring access off or on:**

1. With the desired partition selected, press **B** until the display shows *RING/HANG/RING OFF/ON (current setting)*.
2. Press **1** (off) or **2** (on), then press #. The display begins flashing the entered selection, then stops and displays *RING/HANG/RING OFF/ON (new setting)*.

The following describes how to program the phone

### Hourly Line Test *(Phone Options—Partition 1)* (0212—partition 1 only)

(Default = off) This setting determines whether the panel checks the phone line voltage every hour.

#### Note

The panel must have a Phone Line Monitor card installed for this feature to work.

#### To turn Hourly Line Test off or on:

1. With partition 1 selected, press **B** until the display shows *HOURLY LINE TEST OFF/ON* (*current setting*).
2. Press **1** (off) or **2** (on), then press #. The display flashes the entered setting, then stops after pressing # and displays *HOURLY LINE TEST OFF/ON* (*new setting*).

### Toll Saver *(Phone Options—Partition 1, 2)* (0213—partition 1, 0223—partition 2)

(Default = on) This setting determines whether the panel answers off-site access on the eighth ring (on) or twelfth ring (off), if a trouble condition exists.

#### To turn Toll Saver off or on:

1. With the desired partition selected, press **B** until the display shows *TOLL SAVER OFF/ON* (*current setting*).
2. Press **1** (off) or **2** (on), then press #. The display flashes the entered setting, then stops after pressing # and displays *TOLL SAVER OFF/ON* (*new setting*).

### Phone Panic *(Phone Options—Partition 1, 2)* (0214—partition 1, 0224—partition 2)

(Default = off) This setting determines whether a police panic alarm can be activated from a touch-tone phone.

When turned on, pressing **#** + **\* \* \* \* \*** activates a police panic alarm.

#### To turn Phone Panic off or on:

1. With the desired partition selected, press **B** until the display shows *PHONE PANIC OFF/ON* (*current setting*).
2. Press **1** (off) or **2** (on), then press #. The display flashes the entered setting, then stops after pressing # and displays *PHONE PANIC OFF/ON* (*new setting*).

### Phone Acc. Key *(Phone Options—Partition 1, 2)* (0215—partition 1, 0225—partition 2)

(Default = **#**) This setting determines which touch-tone phone button is used for system access and control (only if a Phone Interface and Voice module is installed). To access the system, the user picks up the phone and within five seconds presses **#**. The panel seizes the phone line and waits for the user to enter security system commands. Phone access can be changed from **#** to **\***.

#### Note

To keep conflicts between the security system and other phone devices and services to a minimum, it is strongly recommended not to change the phone access to **\***. Since many phone devices (answering machines, computer modems, fax machines) and services (call-waiting, call-forwarding, banking transactions) require **\*** to initiate their operation, **#** is set as the default to help reduce conflicts.

#### To change the Phone Access Key:

1. With the desired partition selected, press **B** until the display shows *PHONE ACCESS #/\** (*current setting*).
2. Press **1** (for **\***) or **2** (for **#**), then press #. The display flashes the entered setting, then stops after pressing # and displays *PHONE ACCESS #/\** (*new setting*).

## Timers Menu

The *TIMERS* menu lets you set up the various system feature times that affect the whole system (global) or a specific partition.

The following describes how to program the timer settings that appear under *GLOBAL*.



<b>Supervisory Time</b> <b>(0300)</b>	<i>(Timers—Global)</i>
<p>(Default = random from 01:00 to 05:00) This setting determines what time of day the panel reports supervisory and low battery reports to the central station. The setting is based on a 24-hour timer so a.m. and p.m. settings are not needed.</p> <p><b>Note</b> The panel's clock must be set with the correct time for accurate supervisory time reporting. Refer to the "User Programming" section for setting the panel's clock.</p> <p><b>To set the Supervisory Time:</b></p> <p>With the display showing <i>SUPERVISORY TIME HH:MM</i> (<i>current setting</i>), enter the desired 4-digit time value (for example, enter 0130 to set the supervisory time for 1:30 a.m.), then press #. The display flashes the entered setting, then stops after pressing # and displays <i>SUPERVISORY TIME</i> (<i>new setting</i>).</p>	
<b>RF Tx Timeout</b> <b>(0301)</b>	<i>(Timers—Global)</i>
<p>(Default = 12 hours) This setting determines how many hours (2 - 24) the panel has to receive at least one signal from a wireless sensor (learned into a supervised group). If the panel does not receive a signal from any supervised wireless sensor within the set time, the panel reports a supervisory condition to the central station.</p> <p><b>Note</b> For U.L. Listed commercial installations, the RF Tx Timeout must be set to 4 hours. For U.L. Listed residential installations, the RF Tx Timeout must be set to 24 hours.</p> <p><b>To set the RF Tx Timeout:</b></p> <p>With the display showing <i>RF TX TIMEOUT nn HOURS</i> (<i>current setting</i>), enter the desired 2-digit timeout value (02 - 24), then press #. The display flashes the entered setting, then stops after pressing # and displays <i>RF TX TIMEOUT nn HOURS</i> (<i>new setting</i>).</p>	

<b>Phone Test Freq.</b> <b>(0302)</b>	<i>(Timers—Global)</i>
<p>(Default = 07 days) This setting determines how often the panel sends the automatic phone test (see Auto Phone Test under Phone Options—Global) to the central station or a pager. The phone test frequency can be set to report every 1 to 255 days.</p> <p><b>To set the Phone Test Freq:</b></p> <p>With the display showing <i>PHONE TEST FREQ nnn DAYS</i> (<i>current setting</i>), enter the 3-digit value (001 - 255), then press #. The display flashes the entered setting, then stops after pressing # and displays <i>PHONE TEST FREQ nnn DAYS</i> (<i>new setting</i>).</p>	
<b>Next Phone Test</b> <b>(0303)</b>	<i>(Timers—Global)</i>
<p>(Default = 07 days) This setting determines how many days (001 - 255) until the next automatic phone test occurs. When setting up Phone Test Freq. (see above), Next Phone Test must be set to accurately count the number of days left in the cycle before the next phone test occurs. This setting should be the same or less than the Phone Test Freq. setting.</p> <p><b>To set the Next Phone Test:</b></p> <p>With the display showing <i>NEXT PHONE TEST nnn DAYS</i> (<i>current setting</i>), enter the 3-digit value (001 - 255), then press #. The display flashes the entered setting, then stops after pressing # and displays <i>NEXT PHONE TEST nnn DAYS</i> (<i>new setting</i>).</p>	
<b>Output Trip Time</b> <b>(0304)</b>	<i>(Timers—Global)</i>
<p>(Default = 04 seconds) This setting determines how long onboard, SnapCard, and HOM outputs are activated, when configured for a momentary trip.</p> <p><b>To set the Output Trip Time:</b></p> <p>With the display showing <i>OUTPUT TRIP TIME nn SECONDS</i> (<i>current setting</i>), enter the desired time (1 - 12), then press #. The display flashes the entered setting, then stops after pressing # and displays <i>HOM TRIP TIME nn SECONDS</i> (<i>new setting</i>).</p>	

## Programming the Panel

<b>Activity Timeout</b> <b>(0305)</b>	<i>(Timers—Global)</i>
<p>(Default = 24 hours) This setting determines how long the system goes (01 - 42 hours) without user interaction and device activation before sending a ‘no activity’ report to the central station.</p>	
<b>To set the Activity Timeout:</b>	
<p>With the display showing <i>ENTER ACTIVITY TIME-OUT nn HOURS (current setting)</i> enter the desired 2-digit time value (01 - 42), then press #.</p> <p>The display flashes the entered setting, then stops after pressing # and displays <i>ACTIVITY TIMEOUT nn HOURS (new setting)</i>.</p>	
<b>Daylight Savings</b> <b>(0306)</b>	<i>(Timers—Global)</i>
<p>(Default = on) This setting determines whether the panel’s clock automatically adjusts for daylight savings time changes in spring and fall.</p>	
<b>To turn Daylight Savings off or on:</b>	
<p>With the display showing <i>DAYLIGHT SAVINGS OFF/ON (current setting)</i>, press <b>1</b> (off) or <b>2</b> (on), then press #.</p> <p>The display flashes the entered setting, then stops after pressing # and displays <i>DAYLIGHT SAVINGS OFF/ON (new setting)</i>.</p>	

The following describes how to program the timer settings that appear under *PARTITION 1* and *PARTITION 2*.

<b>Entry Delay</b> <b>(0310—partition 1, 0320—partition 2)</b>	<i>(Timers—Partition 1, 2)</i>
<p>(Default = 032 seconds) This setting determines how much time (32 - 240 seconds) the user has to disarm the system after entering the premises through a designated delay door, to avoid causing an alarm.</p>	
<b>To set the Entry Delay:</b>	
<ol style="list-style-type: none"><li>1. With the desired partition selected, press <b>B</b> until the display shows <i>ENTRY DELAY nnn SECONDS (current setting)</i>.</li><li>2. Enter the desired time value, then press #. The display flashes the entered setting, then stops after pressing # and displays <i>ENTRY DELAY nnn SECONDS (new setting)</i>.</li></ol>	

<b>Exit Delay</b> <b>(0311—partition 1, 0321—partition 2)</b>	<i>(Timers—Partition 1, 2)</i>
<p>(Default = 064 seconds) This setting determines how much time (48 - 184 seconds) the user has to leave the premises through a designated delay door after arming the system, to avoid causing an alarm.</p>	
<b>To set the Exit Delay:</b>	
<ol style="list-style-type: none"><li>1. With the desired partition selected, press <b>B</b> until the display shows <i>EXIT DELAY nnn SECONDS (current setting)</i>.</li><li>2. Enter the desired time value, then press #. The display flashes the entered setting, then stops after pressing # and displays <i>EXIT DELAY nnn SECONDS (new setting)</i>.</li></ol>	
<b>Extended Delay</b> <b>(0312—partition 1, 0322—partition 2)</b>	<i>(Timers—Partition 1, 2)</i>
<p>(Default = 04 minutes) This setting determines how much time (01 - 08 minutes) the user has to enter or exit the premises through a designated extended delay door, without causing an alarm.</p>	
<b>To set the Extended Delay:</b>	
<ol style="list-style-type: none"><li>1. With the desired partition selected, press <b>B</b> until the display shows <i>EXTENDED DELAY nn MINUTES (current setting)</i>.</li><li>2. Enter the desired time value, then press #. The display flashes the entered setting, then stops after pressing # and displays <i>EXTENDED DELAY nn MINUTES (new setting)</i>.</li></ol>	
<b>Siren Timeout</b> <b>(0313—partition 1, 0323—partition 2)</b>	<i>(Timers—Partition 1, 2)</i>
<p>(Default = 04 minutes) This setting determines how long sirens sound (01 - 30 minutes) if no one is present to disarm the system.</p>	
<b>To set the Siren Timeout:</b>	
<ol style="list-style-type: none"><li>1. With the desired partition selected, press <b>B</b> until the display shows <i>SIREN TIMEOUT nn MINUTES (current setting)</i>.</li><li>2. Enter the desired time value, then press #. The display flashes the entered setting, then stops after pressing # and displays <i>SIREN TIMEOUT nn MINUTES (new setting)</i>.</li></ol>	

## Light Control Menu

The *LIGHT CONTROL* menu lets you set up light activation that affects a specific partition.

The following describes how to program the light control settings that appear under *PARTITION 1* and *PARTITION 2*.

### Note

A Power Line Carrier card must be installed on the panel circuit board, the panel must be powered using the Line Carrier Transformer, and X-10 Powerhouse Lamp Modules installed at desired lamps for light control to work.

### Entry Lights *(Light Control—Partition 1, 2)* (0400—partition 1, 0410—partition 2)

(Default = none) This setting determines whether X-10 controlled lights set to numbers 2 - 9 turn on during entry and exit delays.

### Note

X-10 Lamp Modules set to 1 always turn on during the entry and exit delays.

### To set the Entry Lights:

1. With the desired partition selected, press **B** until the display shows *ENTRY LIGHTS nnnnnnnn* (*current setting*).
2. Enter the desired light numbers (2 - 9 based on the UNIT dial setting on each X-10 Lamp Module), then press **#**.  
The display shows *ENTRY LIGHTS nnnnnnnn* (*new setting*).

### To delete Entry Lights:

Enter any light number that appears on the display, then press **#**. The number disappears from the display.

### House Code *(Light Control—Partition 1, 2)* (0401—partition 1, 0411—partition 2)

(Defaults: partition 1 = 01-B; partition 2 = 02-C) This setting determines which Supervised Wireless Sirens and X-10 controlled lights work in a selected partition. The letter that appears after the house code number indicates the necessary HOUSE dial setting for X-10 modules in that partition.

### To set the House Code:

1. With the desired partition selected, press **B** until the display shows *HOUSE CODE nn-x* (*current setting*).
2. Enter the desired number (1 - 255), then press **#**. The display flashes the entered setting, then stops after pressing **#** and displays *HOUSE CODE nn-x* (*new setting*).

## Touchpad Options Menu

The *TOUCHPAD OPTIONS* menu lets you set up touchpad operation that affects the whole system (global) or a specific partition.

The following describes how to program the touchpad option settings that appear under *GLOBAL*.

<b>RFTP Supervision</b> ( <i>Touchpad Options—Global</i> ) <b>(0500)</b>
<p>(Default = off) This setting determines whether the panel monitors for and reports supervisory conditions of Wall-mount Wireless Touchpads.</p> <p>When turned on, the panel monitors Wall-mount Wireless Touchpads for supervisory signals (based on RF TX Timeout setting). If the panel does not receive a supervisory signal from the touchpad within the RF TX Timeout setting or if a low touchpad battery condition is detected, the system alerts users and reports a supervisory condition to the central monitoring station.</p> <p><b>Note</b> The system alerts users if a low battery condition on any wireless touchpad occurs, whether this setting is off or on.</p> <p><b>To turn RFTP Supervision off or on:</b></p> <ol style="list-style-type: none"> <li>1. With the desired partition selected, press <b>B</b> until the display shows <i>RFTP SUPERVISION OFF/ON</i> (<i>current setting</i>).</li> <li>2. Press <b>1</b> (off) or <b>2</b> (on), then press <b>#</b>. The display flashes the entered setting, then stops after pressing <b>#</b> and displays <i>RFTP SUPERVISION OFF/ONN</i> (<i>new setting</i>).</li> </ol>

The following describes how to program the touchpad option settings that appear under *PARTITION 1* and *PARTITION 2*.

<b>Fire Panic</b> ( <i>Touchpad Options—Partition 1, 2</i> ) <b>(0510—partition 1, 0520—partition 2)</b>
<p>(Default = on) This setting determines whether the fire panic buttons are enabled (on) or disabled (off) on touchpads for a selected partition.</p> <p><b>To change the Fire Panic setting:</b></p> <ol style="list-style-type: none"> <li>1. With the desired partition selected, press <b>B</b> until the display shows <i>FIRE PANIC OFF/ON</i> (<i>current setting</i>).</li> <li>2. Press <b>1</b> (off) or <b>2</b> (on), then press <b>#</b>. The display flashes the entered setting, then stops after pressing <b>#</b> and displays <i>FIRE PANIC OFF/ON</i> (<i>new setting</i>).</li> </ol>
<b>Aux. Panic</b> ( <i>Touchpad Options—Partition 1, 2</i> ) <b>(0511—partition 1, 0521—partition 2)</b>
<p>(Default = on) This setting determines whether the auxiliary panic buttons are enabled (on) or disabled (off) on touchpads for a selected partition.</p> <p><b>To change the Auxiliary Panic setting:</b></p> <ol style="list-style-type: none"> <li>1. With the desired partition selected, press <b>B</b> until the display shows <i>AUXILIARY PANIC OFF/ON</i> (<i>current setting</i>).</li> <li>2. Press <b>1</b> (off) or <b>2</b> (on), then press <b>#</b>. The display flashes the entered setting, then stops after pressing <b>#</b> and displays <i>AUXILIARY PANIC OFF/ON</i> (<i>new setting</i>).</li> </ol>
<b>Police Panic</b> ( <i>Touchpad Options—Partition 1, 2</i> ) <b>(0512—partition 1, 0522—partition 2)</b>
<p>(Default = on) This setting determines whether the police panic buttons are enabled (on) or disabled (off) on touchpads for a selected partition.</p> <p><b>To change the Police Panic setting:</b></p> <ol style="list-style-type: none"> <li>1. With the desired partition selected, press <b>B</b> until the display shows <i>POLICE PANIC OFF/ON</i> (<i>current setting</i>).</li> <li>2. Press <b>1</b> (off) or <b>2</b> (on), then press <b>#</b>. The display flashes the entered setting, then stops after pressing <b>#</b> and displays <i>POLICE PANIC OFF/ON</i> (<i>new setting</i>).</li> </ol>

<b>KTP Arm</b> <i>(Touchpad Options—Partition 1, 2)</i> <b>(0513—partition 1, 0523—partition 2)</b>
<p>(Default = off) This setting determines whether keychain touchpads arm the selected partition directly to AWAY with NO DELAY (on) or increments from OFF to STAY, or from STAY to AWAY (off).</p> <p><b>To change the Keychain Touchpad Arming setting:</b></p> <ol style="list-style-type: none"> <li>1. With the desired partition selected, press <b>B</b> until the display shows <i>KEYCHAIN TOUCHPAD ARM OFF/ON (current setting)</i>.</li> <li>2. Press <b>1</b> (off) or <b>2</b> (on), then press <b>#</b>. The display flashes the entered setting, then stops after pressing <b>#</b> and displays <i>KEYCHAIN TOUCHPAD ARM OFF/ON (new setting)</i>.</li> </ol>
<b>Star Is No Delay</b> <i>(Touchpad Options—Partition 1, 2)</i> <b>(0514—partition 1, 0524—partition 2)</b>
<p>(Default = off) This setting determines whether the keychain touchpad star button controls a hardwire output (off) or the NO DELAY feature (on).</p> <p><b>To change the Keychain Star Is No Delay setting:</b></p> <ol style="list-style-type: none"> <li>1. With the desired partition selected, press <b>B</b> until the display shows <i>STAR IS NO DELAY OFF/ON (current setting)</i>.</li> <li>2. Press <b>1</b> (off) or <b>2</b> (on), then press <b>#</b>. The display flashes the entered setting, then stops after pressing <b>#</b> and displays <i>STAR IS NO DELAY OFF/ON (new setting)</i>.</li> </ol>

## Reporting Menu

The *REPORTING* menu lets you set up which system events (global or partition) are reported to the central monitoring station.

The following describes how to program the reporting settings that appear under *GLOBAL*.

<b>24-Hour Tamper</b> <i>(Reporting—Global)</i> <b>(06000)</b>
<p>(Default = off) This setting determines whether the panel sounds sirens and reports a tamper alarm when wireless sensor tamper switches are activated, even when the system is disarmed (OFF).</p> <p><b>To turn 24-Hour Tamper off or on:</b></p> <p>With the display showing <i>24-HOUR TAMPER OFF/ON (current setting)</i>, press <b>1</b> (off) or <b>2</b> (on), then press <b>#</b>.</p> <p>The display flashes the entered setting, then stops after pressing <b>#</b> and displays <i>24-HOUR TAMPER OFF/ON (new setting)</i>.</p>
<b>Buffer Control</b> <i>(Reporting—Global)</i> <b>(06001)</b>
<p>(Default = off) This setting determines whether all system events are logged in the buffer (off) or if only opening and closing reports are logged in the buffer (on).</p> <p><b>To turn Buffer Control off or on:</b></p> <p>With the display showing <i>BUFFER CONTROL OFF/ON (current setting)</i>, press <b>1</b> (off) or <b>2</b> (on), then press <b>#</b>.</p> <p>The display flashes the entered setting, then stops after pressing <b>#</b> and displays <i>BUFFER CONTROL OFF/ON (new setting)</i>.</p>
<b>Back In Service</b> <i>(Reporting—Global)</i> <b>(06002)</b>
<p>(Default = on) This setting determines whether the panel reports to the central station after AC and backup battery power are restored after an extended power outage.</p> <p><b>To turn Back In Service reports off or on:</b></p> <p>With the display showing <i>BACK IN SERVICE OFF/ON (current setting)</i>, press <b>1</b> (off) or <b>2</b> (on), then press <b>#</b>.</p> <p>The display flashes the entered setting, then stops after pressing <b>#</b> and displays <i>BACK IN SERVICE OFF/ON (new setting)</i>.</p>

<b>Low CPU Battery (06003)</b>	<i>(Reporting—Global)</i>
<p>(Default = on) This setting determines whether the panel reports a low panel battery to the central station or pager, before shutting down.</p> <p><b>To turn Low CPU Battery reports off or on:</b></p> <p>With the display showing <i>LOW CPU BATTERY OFF/ON (current setting)</i>, press <b>1</b> (off) or <b>2</b> (on), then press #.</p> <p>The display flashes the entered setting, then stops after pressing # and displays <i>LOW CPU BATTERY OFF/ON (new setting)</i>.</p>	
<b>Battery Restoral (06004)</b>	<i>(Reporting—Global)</i>
<p>(Default = off) This setting determines whether the panel reports to the central monitoring station or pager, when a wireless sensor reports to the panel after battery replacement.</p> <p><b>To turn Battery Restoral reports off or on:</b></p> <p>With the display showing <i>BATTERY RESTORAL OFF/ON (current setting)</i>, press <b>1</b> (off) or <b>2</b> (on), then press #.</p> <p>The display flashes the entered setting, then stops after pressing # and displays <i>BATTERY RESTORAL OFF/ON (new setting)</i>.</p>	
<b>Buffer Full Rpt (06005)</b>	<i>(Reporting—Global)</i>
<p>(Default = off) This setting determines whether the panel sends an event buffer full report to the central monitoring station when the event buffer is nearly full.</p> <p><b>To turn Buffer Full Report off or on:</b></p> <p>With the display showing <i>BUFFER FULL RPT OFF/ON (current setting)</i>, press #.</p> <p>Press <b>1</b> (off) or <b>2</b> (on), then press #.</p> <p>The display flashes the entered setting, then stops after pressing # and displays <i>BUFFER FULL RPT OFF/ON (new setting)</i>.</p>	

<b>Zone Restorals (06006)</b>	<i>(Reporting—Global)</i>
<p>(Default = off) This setting determines whether the panel (before it is disarmed) reports to the central monitoring station or pager when a wireless sensor or hardwire zone is restored to its non-alarm state, after an alarm condition from that sensor or zone.</p> <p><b>To turn Zone Restoral reporting off or on:</b></p> <p>With the display showing <i>ZONE RESTORALS OFF/ON (current setting)</i>, press <b>1</b> (off) or <b>2</b> (on), then press #.</p> <p>The display flashes the entered setting, then stops after pressing # and displays <i>ZONE RESTORAL OFF/ON (new setting)</i>.</p>	
<b>AC Failure (06007)</b>	<i>(Reporting—Global)</i>
<p>(Default = off) This setting determines whether the panel reports to the central station after AC power to the panel is out for 15 minutes.</p> <p><b>To turn AC Failure reports off or on:</b></p> <p>With the display showing <i>AC FAILURE OFF/ON (current setting)</i>, press <b>1</b> (off) or <b>2</b> (on), then press #.</p> <p>The display flashes the entered setting, then stops after pressing # and displays <i>AC FAILURE OFF/ON (new setting)</i>.</p>	
<b>Receiver Failure (06008)</b>	<i>(Reporting—Global)</i>
<p>(Default = off) This setting determines whether the panel reports if no wireless sensor signals have been received for two hours, or if the receiver is being jammed (constant signal).</p> <p><b>Note</b> For U.L. Listed installations that include wireless devices, this feature must be on.</p> <p><b>To turn Receiver Failure reports off or on:</b></p> <p>With the display showing <i>RECEIVER FAILURE OFF/ON (current setting)</i>, press <b>1</b> (off) or <b>2</b> (on), then press #.</p> <p>The display flashes the entered setting, then stops after pressing # and displays <i>RECEIVER FAILURE OFF/ON (new setting)</i>.</p>	

<b>RF Low Bat Rpt (06009)</b>	<i>(Reporting—Global)</i>
<p>(Default = weekly) This setting determines whether the panel reports to the central monitoring station or pager daily or weekly, when a wireless sensor or touchpad reports a low battery condition to the panel.</p> <p><b>To set RF Low Battery Report to daily or weekly:</b></p> <p>With the display showing <i>RF LOW BAT RPT DAILY/WEEKLY</i> (current setting), press <b>1</b> (daily) or <b>2</b> (weekly), then press #.</p> <p>The display flashes the entered setting, then stops after pressing # and displays <i>RF LOW BAT RPT DAILY/WEEKLY</i> (new setting).</p>	
<b>RF Supv Report (06010)</b>	<i>(Reporting—Global)</i>
<p>(Default = weekly) This setting determines whether the panel reports to the central monitoring station or pager daily or weekly, when the panel detects a wireless sensor supervisory condition.</p> <p><b>To set RF Supv Report to daily or weekly:</b></p> <p>With the display showing <i>RF SUPV REPORT DAILY/WEEKLY</i> (current setting), press <b>1</b> (daily) or <b>2</b> (weekly), then press #.</p> <p>The display flashes the entered setting, then stops after pressing # and displays <i>RF SUPV REPORT DAILY/WEEKLY</i> (new setting).</p>	

The following describes how to program the settings that appear under *REPORTING—PARTITION 1* and *PARTITION 2*.

<b>Opening Reports (0610—partition 1, 0620—partition 2)</b>	<i>(Reporting—Partition 1, 2)</i>
<p>(Default = off) This setting determines whether the panel sends an opening report to the central station or pager, after the partition is disarmed.</p> <p><b>Note</b></p> <p>To use this feature, the <i>OPEN/CLOSE REPORTS</i> settings under the <i>PHONES—CS PHONE 1-3</i> and/or <i>PHONES—PAGER PHONE 1-5</i> menus must be turned on for the specific CS Phone or Pager Phone number.</p> <p><b>To turn Opening Reports off or on:</b></p> <ol style="list-style-type: none"> <li>1. With the desired partition selected, press <b>B</b> until the display shows <i>OPENING REPORTS OFF/ON</i> (current setting).</li> <li>2. Press <b>1</b> (off) or <b>2</b> (on), then press #. The display flashes the entered setting, then stops after pressing # and displays <i>OPENING REPORTS OFF/ON</i> (new setting).</li> </ol>	
<b>Closing Reports (0611—partition 1, 0621—partition 2)</b>	<i>(Reporting—Partition 1, 2)</i>
<p>(Default = off) This setting determines whether the panel sends a closing report to the central station or pager, after the partition is armed.</p> <p><b>To turn Closing Reports off or on:</b></p> <ol style="list-style-type: none"> <li>1. With the desired partition selected, press <b>B</b> until the display shows <i>CLOSING REPORTS OFF/ON</i> (current setting).</li> <li>2. Press <b>1</b> (off) or <b>2</b> (on), then press #. The display flashes the entered setting, then stops after pressing # and displays <i>CLOSING REPORTS OFF/ON</i> (new setting).</li> </ol>	
<b>No Activity (0612—partition 1, 0622—partition 2)</b>	<i>(Reporting—Partition 1, 2)</i>
<p>(Default = off) This setting determines whether the panel sends a no activity report to the central station or pager, if there is no system activity within a preset time period (see <i>TIMERS—ACTIVITY TIMEOUT</i>).</p> <p><b>To turn No Activity reports off or on:</b></p> <ol style="list-style-type: none"> <li>1. With the desired partition selected, press <b>B</b> until the display shows <i>NO ACTIVITY OFF/ON</i> (current setting).</li> <li>2. Press <b>1</b> (off) or <b>2</b> (on), then press #. The display flashes the entered setting, then stops after pressing # and displays <i>NO ACTIVITY OFF/ON</i> (new setting).</li> </ol>	

**Duress Option** (Reporting—Partition 1, 2)  
(0613—partition 1, 0623—partition 2)

(Default = off) This setting determines whether the selected partition can be controlled using a programmed duress code (see *SECURITY—PARTITION 1/2—DURESS CODE*).

**Caution**

Because using duress codes often results in false alarms due to code entry errors, it is strongly recommended not to program any duress codes.

If a duress code is absolutely necessary, their use with an Interrogator 200 is highly recommended to reduce false alarms and accidental dispatches.

**To turn Duress Option off or on:**

1. With the desired partition selected, press **B** until the display shows *DURESS OPTION OFF/ON* (current setting).
2. Press **1** (off) or **2** (on), then press #. The display flashes the entered setting, then stops after pressing # and displays *DURESS OPTION OFF/ON* (new setting).

**Force Armed** (Reporting—Partition 1, 2)  
(0614—partition 1, 0624—partition 2)

(Default = off) This setting determines whether the panel reports to the central monitoring station when a sensor/zone is bypassed, directly or indirectly.

**Note**

Auto Force Armed (when the panel arms itself) always reports to the central monitoring station.

**To turn Force Armed off or on:**

1. With the desired partition selected, press **B** until the display shows *FORCE ARMED OFF/ON* (current setting).
2. Press **1** (off) or **2** (on), then press #. The display flashes the entered setting, then stops after pressing # and displays *FORCE ARMED OFF/ON* (new setting).

**Latchkey Format** (Reporting—Partition 1, 2)  
(0615—partition 1, 0625—partition 2)

(Default = off) This setting determines whether the selected partition is set up for basic (off) or advanced (on) latchkey opening report operation.

**Basic:**

- a). If the partition is armed by entering 2 (or 3) + CODE, *disarming using a designated latchkey user code within an assigned time schedule* sends a page.

**or--**

- b). If the partition is armed by entering 2 (or 3) + CODE + 6 (LATCHKEY), *disarming using a designated latchkey user code inside or outside of an assigned time schedule* sends a page.

**Advanced:**

Arming the partition by entering 2 (or 3) + CODE + 6 (LATCHKEY), and then *disarming using a latchkey designated user code within an assigned time schedule* sends a page.

Refer to the *User's Guide* for complete Latchkey setup and operation.

**To turn Latchkey Format off or on:**

1. With the desired partition selected, press **B** until the display shows *LATCHKEY FORMAT OFF/ON* (current setting).
2. Press **1** (off—basic) or **2** (on—advanced), then press #. The display flashes the entered setting, then stops after pressing # and displays *LATCHKEY FORMAT OFF/ON* (new setting).

**Freeze Alarm** (Reporting—Partition 1, 2)  
(0616—partition 1, 0626—partition 2)

(Default = off) This setting determines whether the panel reports a freeze alarm to the central station or pager, when the selected partition's energy saver module detects a temperature that matches a predetermined setting (see *BUS DEVICES—UNIT TYPE nn ESM—PARTITION 1/2—FREEZE TEMP*).

**To turn Freeze Alarm reporting off or on:**

1. With the desired partition selected, press **B** until the display shows *FREEZE ALARM OFF/ON* (current setting).
2. Press **1** (off) or **2** (on), then press #. The display flashes the entered setting, then stops after pressing # and displays *FREEZE ALARM OFF/ON* (new setting).



**Alarm Verify** (Reporting—Partition 1, 2)  
(0617—partition 1, 0627—partition 2)

(Default = off) This setting determines whether the panel goes into alarm and reports after a single sensor/zone trip (off) or waits for a second trip signal (on).

**Note**

This setting applies only to sensors/zones learned into groups 10 - 20. If Alarm Verify is set to on, group 18 responds the same as group 17. See "Appendix A, Table A.5: Sensor Group Characteristics."

**To turn Alarm Verify off or on:**

1. With the desired partition selected, press **B** until the display shows *ALARM VERIFY OFF/ON (current setting)*.
2. Press **1** (off) or **2** (on), then press **#**. The display flashes the entered setting, then stops after pressing **#** and displays *ALARM VERIFY OFF/ON (new setting)*.

**System Tamper** (Reporting—Partition 1, 2)  
(0618—partition 1, 0628—partition 2)

(Default = off) This setting determines whether the armed partition goes into alarm if several incorrect access codes (40 consecutive keypresses) are entered. This setting also determines whether the panel reports to the central station if a bus device stops communicating with the panel.

**To change the System Tamper setting:**

1. With the desired partition selected, press **B** until the display shows *SYSTEM TAMPER OFF/ON (current setting)*.
2. Press **1** (off) or **2** (on), then press **#**. The display flashes the entered setting, then stops after pressing **#** and displays *FIRE PANIC OFF/ON (new setting)*.

## Siren Options Menu

The *SIREN OPTIONS* menu lets you set up siren operation that affects the whole system (global) or a specific partition.

The following describes how to program the siren option settings that appear under *GLOBAL*.

**Immediate Beeps** (Siren Options—Global)  
(0700)

(Default = off) This setting determines whether the panel activates trouble beeps immediately, once a wireless sensor supervisory condition is detected.

**Note**

For UL Listed installations, this feature must be on.

**To turn Immediate Beeps off or on:**

With the display showing *IMMEDIATE BEEPS OFF/ON (current setting)*, press **1** (off) or **2** (on), then press **#**. The display flashes the entered setting, then stops after pressing **#** and displays *IMMEDIATE BEEPS OFF/ON (new setting)*.

**Disable Tr Beeps** (Siren Options—Global)  
(0701)

(Default = off) This setting determines whether the panel activates trouble beeps when a wireless sensor supervisory condition is detected.

**Note**

For UL Listed installations, this feature must be off.

**To turn Disable Trouble Beeps off or on:**

With the display showing *DISABLE TR BEEPS OFF/ON (current setting)*, press **1** (off) or **2** (on), then press **#**. The display flashes the entered setting, then stops after pressing **#** and displays *DISABLE TR BEEPS OFF/ON (new setting)*.

**UL 98 Options** (Siren Options—Global)  
(0702)

(Default = off) This setting determines whether the panel complies with UL 98 requirements (4-hour trouble beep restart, 4-hour backup battery test, 4-hour smoke (group 26) supervisory zone).

**Note**

For UL Listed installations, this feature must be on.

**To turn UL 98 Options off or on:**

With the display showing *UL 98 OPTIONS OFF/ON (current setting)*, press **1** (off) or **2** (on), then press **#**. The display flashes the entered setting, then stops after pressing **#** and displays *UL 98 OPTIONS OFF/ON (new setting)*.

### SWS Supv Code (Siren Options—Global) (0703)

(Default = 003) This setting determines the system house code number used for supervising wireless sirens.

#### Note

To supervise wireless sirens, the system must include a SuperBus RF Receiver and the siren must be learned into sensor group 33 for the system to process radio signals from wireless sirens.

Supervised Wireless Sirens receive signals from the panel through the existing electrical wiring. If sirens fail to receive or process these signals, the siren transmits a wireless signal to the SuperBus RF Receiver connected to the panel.

#### To set the SWS Supv Code:

With the display showing *SWS SUPV CODE nnn* (*current code*), enter the desired code (1 - 255), then press #.  
The display flashes the entered code, then stops after pressing # and displays *SWS SUPV CODE nnn* (*new code*).

### Global Fire (Siren Options—Global) (0704)

(Default = off) This setting determines whether sirens in both partitions sound (on) if either partition activates a fire alarm.

#### To turn Global Fire off or on:

With the display showing *GLOBAL FIRE OFF/ON* (*current setting*), press **1** (off) or **2** (on), then press #.  
The display flashes the entered setting, then stops after pressing # and displays *GLOBAL FIRE OFF/ON* (*new setting*).

The following describes how to program the settings that appear under *SIREN OPTIONS—PARTITION 1*

### Siren Verify (Siren Options—Partition 1) (0710)

(Default = off) This setting determines whether the panel monitors speakers connected to panel terminals 7 and 8.

#### Note

For UL Listed installations, this feature must be on.

#### To turn Siren Verify off or on:

With the display showing *SIREN VERIFY OFF/ON* (*current setting*), press **1** (off) or **2** (on), then press #.  
The display flashes the entered setting, then stops after pressing # and displays *SIREN VERIFY OFF/ON* (*new setting*).

## Sensors Menu

The *SENSORS* menu gives you access to the following:

- *LEARN SENSORS*—lets you learn hardware zones and wireless sensors into panel memory and assign zones/sensors to specific partitions.
- *SENSOR TEXT*—lets you program sensor text for zone/sensor identification.
- *DELETE SENSORS*—lets you delete zones/sensors from panel memory.
- *VIEW SENSORS*—lets you see current group, sensor number, text assignments of learned sensors/zones, identifies whether zone is wireless or hardware, and indicates N/C or N/O configuration.

The following describes how to program the sensor settings that appear under *LEARN SENSORS*.

**Learn Sensors (080)** (Sensors)

(Default = none) The following describes how to learn hardwire zones and wireless sensors into panel memory.

**To Learn Sensors into panel memory:**

1. With the display showing *SENSORS*, press # and the display shows *LEARN SENSORS*.
2. Press # and the display shows *SENSOR PTN 1*.
3. Press # to select partition 1 or press 2 + # to select partition 2. The display should show *SENSOR GROUP 00*.
4. Enter the desired 2-digit sensor group + # (see Table A.5 in “Appendix A” for a description of all sensor group characteristics). The display shows *TRIP SENSOR nn*, where nn is the displayed (next available) sensor number.
5. To change the displayed sensor number, enter the desired 2-digit sensor number, then press #.
6. With the desired sensor number displayed, trip the sensor or zone as follows:
  - **Hardwire Zones**—trip the zone into the alarm state.
  - **Wireless Sensors**—follow the instructions included with each sensor.
  - **Wireless Door/Window Sensors with External Contacts**—place the external contact in the alarm condition, then activate the sensor’s tamper switch.
  - **Supervised Wireless Sirens**—connect the siren battery then plug the siren into an electrical outlet.

**Note**

Before learning Supervised Wireless Sirens, you must first program a partition house code (see *LIGHT CONTROL* menu) and the SWS house code (see *SIREN OPTIONS* menu).

7. Continue tripping sensors to learn them into the selected sensor group and partition. To stop learning sensors into this group and partition, press \* twice and start again from step 2 (*LEARN SENSORS*) to learn sensors into another group and partition.

**Sensor Text (081)** (Sensors)

(Default = none) Use the following guidelines for programming text to identify zone/sensor locations.

- There are 16 character/word locations or “Item Numbers” for each zone/sensor name. Item numbers for each character/word appear on the next page.
- If a desired word does not appear in the list, create it using characters (custom text). *However, custom text is not spoken by the panel. Instead, a pause in speech occurs in the voice message.*
- When using words, spaces between them appear automatically. When creating words using characters, you must reserve an item number for a ‘space’ after creating the word.
- Each character or word uses up one item number. For example, a word from the list counts as one item number. A created word, such as BOY’S counts as six item numbers—4 letters, 1 apostrophe, and 1 space.
- Plan ahead before programming sensor text. You may need to abbreviate words you create, to avoid running out of item numbers.

**To program Sensor Text:**

1. With the display showing *LEARN SENSORS*, press **B** until the display shows *SENSOR TEXT*.
2. Press # and the display shows *TEXT FOR SN 01*.
3. Press # and the display shows:  
*Sn 01 ITEM 00*  
*000 -*  
where *ITEM 00* is the first character/word location and *000* is the 3-digit character/word number.
4. Enter the 3-digit number of the desired character/word or scroll forward through the numbers by pressing **B** or backward by pressing **A**. If you make a mistake, simply enter the correct 3-digit number or continue scrolling through choices.
5. Press # to accept the displayed choice and the display shows:  
*Sn 01 ITEM 01*  
*000 -*
6. Repeat steps 4 and 5 as needed to complete the zone/sensor name.
7. Press \* after entering the last 3-digit character/word number. The display shows the complete text name. For example:  
*TEXT FOR SN 01*  
*FRONT ENTRY DOOR*

## Programming the Panel

Sensor Text Word Item Numbers	
001—Aborted	047—Detector
002—AC	048—Dining
003—Access	049—Disarmed
004—Active	050—Door
005—Activity	051—Down
006—Alarm	052—Download
007—All	053—Downstairs
008—AM	054—Drawer
009—Area	055—Driveway
010—Arm	056—Duct
011—Armed	057—Duress
012—Arming	058—East
013—Attic	059—Energy Saver
014—Auxiliary	060—Enter
015—Away	061—Entry
016—Baby	062—Error
017—Back	063—Exit
018—Bar	064—Exterior
019—Basement	065—Factory
020—Bathroom	066—Failure
021—Battery	067—Family
022—Bedroom	068—Father’s
023—Bottom	069—Feature
024—Breezeway	070—Fence
025—Building	071—Fire
026—Bus	072—First
027—Bypass	073—Floor
028—Bypassed	074—Force
029—Cabinet	075—Foyer
030—Canceled	076—Freeze
031—Car	077—Front
032—Carbonmonoxide	078—Furnace
033—Central	079—Gallery
034—Chime	080—Garage
035—Closed	081—Gas
036—Closet	082—Glass
037—Closing	083—Goodbye
038—Code	084—Hallway
039—Computer	085—Heat
040—Control	086—Hello
041—Date	087—Help
042—Daughter’s	088—High
043—Degrees	089—Home
044—Delay	090—House
045—Den	091—In
046—Desk	092—Install

Sensor Text Word Item Numbers		
093—Interior	139—Pool	185—0
094—Intrusion	140—Porch	186—1
095—Invalid	141—Power	187—2
096—Is	142—Press	188—3
097—Key	143—Program	189—4
098—Kids	144—Progress	190—5
099—Kitchen	145—Quiet	191—6
100—Latchkey	146—Rear	192—7
101—Laundry	147—Receiver	193—8
102—Left	148—Report	194—9
103—Level	149—RF	195—A
104—Library	150—Right	196—B
105—Light	151—Room	197—C
106—Lights	152—Safe	198—D
107—Living	153—Schedule	199—E
108—Load	154—Screen	200—F
109—Loading	155—Second	201—G
110—Low	156—Sensor	202—H
111—Lower	157—Service	203—I
112—Main	158—Shed	204—J
113—Master	159—Shock	205—K
114—Mat	160—Side	206—L
115—Medical	161—Siren	207—M
116—Memory	162—Sliding	208—N
117—Menu	163—Smoke	209—O
118—Mother’s	164—Son’s	210—P
119—Motion	165—Sound	211—Q
120—No	166—South	212—R
121—North	167—Special	213—S
122—Not	168—Stairs	214—T
123—Now	169—Stay	215—U
124—Number	170—Supervisory	216—V
125—Off	171—System	217—W
126—Office	172—Tamper	218—X
127—OK	173—Temperature	219—Y
128—On	174—Test	220—Z
129—Open	175—Time	221— (space)
130—Opening	176—To	222—’(apostrophe)
131—Panic	177—Touchpad	223— - (dash)
132—Partition	178—Trouble	224— _ (underscore)
133—Patio	179—Unbypass	225— *
134—Pet	180—Unit	226— #
135—Phone	181—Up	227— :
136—Please	182—West	228— /
137—PM	183—Window	229— ?
138—Police	184—Zone	

<b>Delete Sensors</b> <b>(082)</b>	<i>(Sensors)</i>
<p>(Default = none) The following describes how to hard-wire zone and wireless sensor numbers from panel memory.</p> <p><b>Note</b> Deleting sensors does not delete sensor text associated with the deleted sensor number. To delete sensor text, enter the SENSOR TEXT menu and enter 000 (nulls) for each item number.</p> <p><b>To Delete Sensors from panel memory:</b></p> <ol style="list-style-type: none"> <li>1. With the display showing <i>LEARN SENSORS</i>, press <b>B</b> until the display shows <i>DELETE SENSORS</i>.</li> <li>2. Press # and the display shows <i>DELETE SN NN</i> (<i>lowest zone/sensor number in panel memory</i>).</li> <li>3. Press # to delete the displayed sensor or enter the desired sensor number, then press #. The display flashes the entered number, then stops and shows <i>DELETE SENSOR NN DONE</i>.</li> </ol> <p>Repeat steps 2 and 3 until all desired sensors are deleted.</p>	
<b>Delete Sensors</b> <b>(083)</b>	<i>(Sensors)</i>
<p>(Default = none) This menu lets you view the assignments for each learned zone/sensor. For example, the display shows:</p> <p style="text-align: center;"><i>S01 P1 G13 NC BACK DOOR</i></p> <p>where S01 = zone/sensor number, P1 = partition 1, G13 = sensor group 13, NC = normally closed, HW = hard-wired, and DEN DOOR is the programmed text name.</p> <p><b>To View Sensors:</b></p> <ol style="list-style-type: none"> <li>1. With the display showing <i>LEARN SENSORS</i>, press <b>B</b> until the display shows <i>VIEW SENSORS</i>.</li> <li>2. Press # and the display shows the lowest sensor number zone/sensor assignments.</li> <li>3. Press <b>A</b> or <b>B</b> to scroll through all learned zone/sensor number assignments.</li> </ol>	

## Audio Verification Menu

The *AUDIO VERIFICATION* menu lets you set up Interrogator 200 operation in partition 1, which is the only partition that supports the Interrogator 200.

The following describes how to program the audio verification settings that appear under *PARTITION 1*

<b>Audio Verification</b> <b>(0900)</b>	<i>(Partition 1)</i>
<p>(Default = off) This setting determines whether the system can be accessed by phone for alarm verification, using an Interrogator 200.</p> <p><b>To turn Audio Verification off or on:</b></p> <ol style="list-style-type: none"> <li>1. With the display showing <i>AUDIO VERIFICATION</i>, press #. The display shows <i>PARTITION 1</i>.</li> <li>2. Press # again and the display shows <i>AUDIO VERIFY OFF/ON</i> (<i>current setting</i>).</li> <li>3. Press <b>1</b> (off) or <b>2</b> (on), then press #. The display flashes the entered setting, then stops after pressing # and displays <i>AUDIO VERIFY OFF/ON</i> (<i>new setting</i>).</li> </ol>	
<b>Audio Mode</b> <b>(0901)</b>	<i>(Audio Verification—Partition 1)</i>
<p>(Default = 01) This setting determines how the Interrogator 200 operates. Choose one of the following:</p> <ul style="list-style-type: none"> <li>• <b>(01) Instant</b>—Allows the central station operator instant access for an audio session by entering the AVM code or by pressing <input type="checkbox"/> (if an AVM access code is not programmed), upon completion of panel alarm report.</li> <li>• <b>(02) Callback</b>—allows the central station operator to contact persons on the premises after one ring and verify the alarm report. Operator must press <input type="checkbox"/> or enter the AVM access code within 20 seconds after ring. The panel does not report any alarms during the AVM session, except for fire alarms.</li> <li>• <b>(03) Callback Silent</b>—same as Callback except premises phones do not ring.</li> </ul> <p><b>To set Audio Mode:</b></p> <ol style="list-style-type: none"> <li>1. With the display showing <i>AUDIO VERIFICATION OFF/ON</i>, press <b>B</b> until the display shows <i>AUDIO MODE nn</i> (<i>current setting</i>).</li> <li>2. Enter the desired mode number (01 - 03), then press #. The display flashes the entered setting, then stops after pressing # and displays <i>AUDIO MODE nn</i> (<i>new setting</i>).</li> </ol>	

<b>Fire Shutdown</b> (Audio Verification—Partition 1) <b>(0902)</b>
(Default = off) This setting determines whether system sirens turn off during a fire alarm audio session.
<b>To turn Fire Shutdown off or on:</b>
<ol style="list-style-type: none"> <li>1. With the display showing <i>AUDIO VERIFICATION OFF/ON</i>, press <b>B</b> until the display shows <i>FIRE SHUTDOWN OFF/ON (current setting)</i>.</li> <li>2. Press <b>1</b> (off) or <b>2</b> (on), then press <b>#</b>. The display flashes the entered setting, then stops after pressing <b>#</b> and displays <i>FIRE SHUTDOWN OFF/ON (new setting)</i>.</li> </ol>
<b>Silent Talkback</b> (Audio Verification—Partition 1) <b>(0903)</b>
(Default = off) This setting determines whether the central station operator can speak to persons on the premises (off) or only listen (on) during a silent or duress alarm audio session.
<b>To turn Silent Talkback off or on:</b>
<ol style="list-style-type: none"> <li>1. With the display showing <i>AUDIO VERIFICATION OFF/ON</i>, press <b>B</b> until the display shows <i>SILENT TALKBACK OFF/ON (current setting)</i>.</li> <li>2. Press <b>1</b> (off) or <b>2</b> (on), then press <b>#</b>. The display flashes the entered setting, then stops after pressing <b>#</b> and displays <i>SILENT TALKBACK OFF/ON (new setting)</i>.</li> </ol>
<b>Access Timeout</b> (Audio Verification—Partition 1) <b>(0904)</b>
(Default = 90 seconds) This setting determines how much time (30 - 300 seconds, in 2-second increments) the central station operator has to enter the AVM access code, after the panel is accessed for an audio session (instant mode only).
<b>To change the Access Timeout:</b>
<ol style="list-style-type: none"> <li>1. With the display showing <i>AUDIO VERIFICATION OFF/ON</i>, press <b>B</b> until the display shows <i>ACCESS TIMEOUT nn SECS (current setting)</i>.</li> <li>2. Enter the desired time, then press <b>#</b>. The display flashes the entered setting, then stops after pressing <b>#</b> and displays <i>ACCESS TIMEOUT nn SECS (new setting)</i>.</li> </ol>

<b>Beep Delay</b> (Audio Verification—Partition 1) <b>(0905)</b>
(Default = 02 seconds) This setting determines how long AVM access beeps are delayed (0 - 300 seconds, in 2-second intervals) at the beginning of a 2-way audio session.
<b>To change the Beep Delay:</b>
<ol style="list-style-type: none"> <li>1. With the display showing <i>AUDIO VERIFICATION OFF/ON</i>, press <b>B</b> until the display shows <i>BEEP DELAY nn SECS (current setting)</i>.</li> <li>2. Enter the desired time, then press <b>#</b>. The display flashes the entered setting, then stops after pressing <b>#</b> and displays <i>BEEP DELAY nn SECS (new setting)</i>.</li> </ol>
<b>Access Code</b> (Audio Verification—Partition 1) <b>(0906)</b>
(Default = none) This setting determines the code required to access the Interrogator 200 to start an audio session. If no code is programmed, pressing <b>ⓧ</b> starts an audio session.
<b>To change the Access Code:</b>
<ol style="list-style-type: none"> <li>1. With the display showing <i>AUDIO VERIFICATION OFF/ON</i>, press <b>B</b> until the display shows <i>ACCESS CODE nnnn (current code)</i>.</li> <li>2. Enter the desired 4-digit access code, then press <b>#</b>. The display flashes the entered code, then stops after pressing <b>#</b> and displays <i>ACCESS CODE nnnn (new code)</i>.</li> </ol>

## Accessory Modules Menu

The *ACCESSORY MODULES* menu gives you access to the following:

- *BUS DEVICES*—this menu lets you read bus device unit numbers, assign bus devices to a partition, and other features associated with a specific bus device.
- *SNAPCARD*—this menu lets you assign Snap-Card outputs to a partition and set the configuration number for each output.

The following describes how to program the settings that appear under *ACCESSORY MODULES—BUS DEVICES*.

### Note

Most settings under *ACCESSORY MODULES—BUS DEVICES* have no shortcut numbers.

**Unit - Type** (Acc. Modules—Bus Devices)  
(1000 thru 1015)

(Default = none) This menu lets you identify all connected bus devices, their device address, and lets you set up partition assignment and other configurations based on a specific device. You can also delete learned bus device addresses.

**To identify bus device Unit and Type:**

1. With the display showing *BUS DEVICES*, press #. The display identifies the bus device set to unit number 00. For example:  
*UNIT TYPE*  
*00—LTP*
2. Press **A** or **B** to identify all other bus device unit numbers (0-15) and types (LED Touchpad = LTP, Alphanumeric Touchpad = ATP, Energy Saver Module = ESM, Hardwire Input Module = HIM, Hardwire Output Module = HOM, Phone Interface & Voice Module = PIV, SuperBus RF Receiver = RCVR, no device = NONE).

**To delete learned bus device unit numbers:**

1. With the display showing *BUS DEVICES*, press #. The display shows the bus device set to unit number 00.
2. Press **A** or **B** until the bus device unit number you want to delete is displayed.
3. Press **D**. The display changes the unit number to *NONE*.

**Ptn Assignment** (Acc. Modules—Bus Devices)

(Default = 1) This menu lets you assign bus devices to work in the desired partition.

**Note**

Hardwire Input Modules, Hardwire Output Modules, and SuperBus RF Receivers are not assigned to partitions.

**To assign bus devices to partitions:**

1. With the display showing the desired bus device, press #. The display shows *PARTITION ASSIGN n*.
2. Press **1** or **2** to select the desired partition, then press #.  
The display flashes the entered selection and then stops, confirming the change.

**Status Beeps** (Acc. Modules—Bus Devices)

(Default = on) This setting determines whether the selected touchpad sounds status beeps. Each touchpad can be set individually. This feature is usually turned off if a touchpad is located in or near bedrooms, to avoid disturbing persons sleeping.

**To turn touchpad Status Beeps on or off:**

1. With the display showing the desired touchpad, press # then **B** once. The display shows *STATUS BEEPS OFF/ON (current setting)*.
2. Press **1** (off) or **2** (on) to select the desired setting, then press #.  
The display flashes the entered selection, then stops after pressing # and shows *STATUS BEEPS OFF/ON (new setting)*.

**Key Beeps** (Acc. Modules—Bus Devices)

(Default = on) This setting determines whether selected touchpads sound beeps when their buttons are pressed. This feature is usually turned off if a touchpad is located in or near bedrooms, to avoid disturbing persons sleeping.

**To turn Key Beeps on or off:**

1. With the display showing the desired touchpad, press # then **B** twice. The display shows *KEY BEEPS OFF/ON (current setting)*.
2. Press **1** (off) or **2** (on) to select the desired setting, then press #.  
The display flashes the entered selection, then stops after pressing # and shows *KEY BEEPS OFF/ON (new setting)*.

**Freeze Temp** (Acc. Modules—Bus Devices)

(Default = 42°F) This setting determines the temperature point that the Energy Saver Module detects a potential freeze (heating failure) condition. The adjustable range is from 40°F - 90°F.

**To change the Freeze Temp setting:**

1. With the display showing *UNIT nn TYPE ESM*, press # then **B**. The display shows *FREEZE TEMP nn DEGREES (current setting)*.
2. Enter the desired 2-digit temperature (40 - 90), then press #.  
The display flashes the entered selection, then stops after pressing # and shows *FREEZE TEMP nn DEGREES (new setting)*.

### Temperature *(Acc. Modules—Bus Devices)*

(Default = none) This setting lets you adjust the ESM room temperature setting to match the premises thermostat. The adjustable range is from 40°F - 90°F.

#### Note

To ensure accuracy, wait at least 30 minutes before setting the ESM temperature to allow the ESM to warm or cool to actual room temperature.

#### To change the ESM Temperature setting:

1. With the display showing *UNIT nn TYPE ESM*, press # then **B** twice. The display shows *TEMPERATURE nn DEGREES (current setting)*.
2. Enter the desired 2-digit temperature (40 - 90), then press #.  
The display flashes the entered selection, then stops after pressing # and shows *TEMPERATURE nn DEGREES (new setting)*.

### Relay 1, 2, 3, 4 *(Acc. Modules—Bus Devices)*

(Default = none) This setting lets you assign Hardwire Output Module (HOM) relay outputs to partitions and assign the 5-digit configuration number for each relay output, that determines which system event activates the output and the duration or time the output is activated.

The first three digits represent the trigger number of an event such as, an alarm, open sensor, or arming the system.

The last two digits represent how the output responds such as, momentary, sustained (or latched), or for a preset time.

Tables 6 - 10 on pages 50 thru 53 identify system event trigger and response numbers.

#### To assign HOM Relay outputs to partitions and set their configuration numbers:

1. With the display showing *UNIT nn TYPE HOM*, press #. The display shows *RELAY 1*.
2. Press **A** or **B** to select the desired relay (1 - 4), then press #. The display shows *PARTITION ASSIGN 1*.
3. Press **1** or **2** to select the desired partition assignment for this relay, then press #.  
The display flashes the entered selection, then stops after pressing # and shows *PARTITION ASSIGN n (new setting)*
4. Press **B** and the display shows *CONFIGURATION nnnnn (current setting)*.
5. Enter the desired 5-digit configuration number for this relay, then press #.  
The display flashes the entered number, then stops after pressing # and shows *CONFIGURATION nnnnn (new setting)*.



The following describes how to program the settings that appear under *SNAPCARDS*.

**Relay 1, 2, 3, 4** (Acc. Modules—SnapCards)  
(101XY where X = relay 1 thru 4; Y = partition/configuration number)

(Default = none) This setting lets you assign SnapCard relay outputs to partitions and assign the 5-digit configuration number for each relay output, that determines which system event activates the output and the duration or time the output is activated.

The first three digits represent the trigger number of an event such as, an alarm, open sensor, or arming the system.

The last two digits represent how the output responds such as, momentary, sustained (or latched), or for a preset time.

Tables 6 - 10 on pages 50 thru 53 identify system event trigger and response numbers.

**To assign SnapCard Relay outputs to partitions and set their configuration numbers:**

1. With the display showing *SNAPCARDS*, press #. The display shows *RELAY 1*.
2. Press **A** or **B** to select the desired relay (1 - 4), then press #. The display shows *PARTITION ASSIGN n* (current setting).
3. Press **1** or **2** to select the desired partition assignment for this relay, then press #. The display flashes the entered selection, then stops after pressing # and shows *PARTITION ASSIGN n* (new setting).
4. Press **B** and the display shows *CONFIGURATION nnnnn* (current setting).
5. Enter the desired 5-digit configuration number for this relay, then press #. The display flashes the entered number, then stops after pressing # and shows *CONFIGURATION nnnnn* (new setting).

## Onboard Options Menu

The *ONBOARD OPTIONS* menu lets you set up the following built-in options:

*INPUTS*—this menu lets you set panel zone input 8 for 2-wire smoke operation and turn the smoke verification feature off/on.

*OUTPUTS*—this menu lets you assign the panel's two built-in outputs to partitions and set their configuration numbers.

The following describes how to program the settings that appear under *ONBOARD OPTIONS—INPUTS*.

**Smoke Verify** (Onboard Options—Inputs)  
(1100)

(Default = off) This setting determines whether the panel requires two alarm signals within five minutes (on) from hardwire smoke detectors connected to panel zone inputs 1 - 8 and SnapCard zone inputs, before activating system sirens and reporting to a central station or pager.

**To turn Smoke Verify off or on:**

1. With the display showing *ONBOARD OPTIONS*, press #. The display shows *SMOKE VERIFY OFF/ON* (current setting).
2. Press **1** (off) or **2** (on), then press #. The display flashes the entered number, then stops after pressing # and shows *SMOKE VERIFY OFF/ON* (new setting).

**Two-Wire Smoke** (Onboard Options—Inputs)  
(1101)

(Default = off) This setting determines whether panel zone input 8 is set up for 2-wire smoke detectors (on) or for standard intrusion or 4-wire smoke detectors (off).

**To turn Two-Wire Smoke off or on:**

1. With the display showing *ONBOARD OPTIONS*, press #. The display shows *TWO WIRE SMOKE OFF/ON* (current setting).
2. Press **1** (off) or **2** (on), then press #. The display flashes the entered number, then stops after pressing # and shows *TWO WIRE SMOKE OFF/ON* (new setting).

**Output 1, 2. (Onboard Options—Output 1, 2)  
(11XY where X = output 1 or 2; Y = partition/configuration number)**

(Default: Output 1 = 01400, Output 2 = 00410) This setting lets you assign the selected output to a specific partition and assign the 5-digit configuration number that determines which system event activates the output and the duration or time the output is activated.

The first three digits represent the trigger number of an event such as, an alarm, open sensor, or arming the system.

The last two digits represent how the output responds such as, momentary, sustained (or latched), or for a preset time.

Tables 6 - 10 on pages 50 thru 53 identify system event trigger and response numbers.

**To set up onboard Output 1 & 2 partition and configuration assignments:**

1. With the display showing *ONBOARD OPTIONS*, press #. The display shows *INPUTS*.
2. Press **A** or **B** to select output 1 or 2, then press #. The display shows *PARTITION ASSIGN n (current setting)*.
3. Press 1 or 2 to assign the output to the desired partition, then press #. The display shows *PARTITION ASSIGN (new setting)*.
4. Press **B** and the display shows *CONFIGURATION nnnn (current setting)*.
5. Enter the desired configuration number, then press #. The display flashes the entered number, then stops after pressing # and shows *CONFIGURATION nnnnn (new setting)*.

**Table 6. System Event Trigger Numbers**

System Event	Trigger No.
Fire Alarm	001
Police Alarm	002
Auxiliary Alarm	003
Any Audible Alarm	004
Silent Alarm (sensor groups 2, 3, and duress)	005
Any Audible or Silent Alarm	006
HOM Group 27, 28, 32 in Alarm	007
Major Trouble (fail-to-communicate or receiver failure)	008
Arming to STAY or AWAY	009
Arming to AWAY	010
AVM is Interactive (audio session in progress)	011
Fail-to-Communicate (panel can't call CS or pager)	012
Partition 2 AVM Trip	013
Keychain Touchpad Star Button-Press	014
Smoke Power (for resetting 4-wire smoke detectors)	015

**Table 7. Sensor Group Event Trigger Numbers**

Sensor Group	Trigger No.
Group 00 in alarm	064
Group 01 in alarm	065
Group 02 in alarm	066
Group 03 in alarm	067
Group 04 in alarm	068
Group 05 in alarm	069
Group 06 in alarm	070
Group 07 in alarm	071
Group 08 in alarm	072
Group 09 in alarm	073
Group 10 in alarm	074
Group 11 in alarm	075
Group 12 in alarm	076
Group 13 in alarm	077
Group 14 in alarm	078
Group 15 in alarm	079
Group 16 in alarm	080
Group 17 in alarm	081
Group 18 in alarm	082
Group 19 in alarm	083
Group 20 in alarm	084
Group 21 in alarm	085
Group 22 in alarm	086
Group 23 in alarm	087
Group 24 in alarm	088
Group 25 in alarm	089
Group 26 in alarm	090
Group 27 in alarm	091
Group 28 in alarm	092
Group 32 in alarm	096

**Table 8. Sensor Number Event Trigger Numbers**

Sensor Number	State	Trig-ger No.	State	Trig-ger No.
Sensor 01	in alarm	129	open	229
Sensor 02	in alarm	130	open	230
Sensor 03	in alarm	131	open	231
Sensor 04	in alarm	132	open	232
Sensor 05	in alarm	133	open	233
Sensor 06	in alarm	134	open	234
Sensor 07	in alarm	135	open	235
Sensor 08	in alarm	136	open	236
Sensor 09	in alarm	137	open	237
Sensor 10	in alarm	138	open	238
Sensor 11	in alarm	139	open	239
Sensor 12	in alarm	140	open	240
Sensor 13	in alarm	141	open	241
Sensor 14	in alarm	142	open	242
Sensor 15	in alarm	143	open	243
Sensor 16	in alarm	144	open	244
Sensor 17	in alarm	145	open	245
Sensor 18	in alarm	146	open	246
Sensor 19	in alarm	147	open	247
Sensor 20	in alarm	148	open	248
Sensor 21	in alarm	149	open	249
Sensor 22	in alarm	150	open	250
Sensor 23	in alarm	151	open	251
Sensor 24	in alarm	152	open	252
Sensor 25	in alarm	153	open	253
Sensor 26	in alarm	154	open	254
Sensor 27	in alarm	155	open	255
Sensor 28	in alarm	156	open	256
Sensor 29	in alarm	157	open	257
Sensor 30	in alarm	158	open	258
Sensor 31	in alarm	159	open	259
Sensor 32	in alarm	160	open	260
Sensor 33	in alarm	161	open	261
Sensor 34	in alarm	162	open	262

**Table 8. Sensor Number Event Trigger Numbers**

Sensor Number	State	Trig-ger No.	State	Trig-ger No.
Sensor 35	in alarm	163	open	263
Sensor 36	in alarm	164	open	264
Sensor 37	in alarm	165	open	265
Sensor 38	in alarm	166	open	266
Sensor 39	in alarm	167	open	267
Sensor 40	in alarm	168	open	268
Sensor 41	in alarm	169	open	269
Sensor 42	in alarm	170	open	270
Sensor 43	in alarm	171	open	271
Sensor 44	in alarm	172	open	272
Sensor 45	in alarm	173	open	273
Sensor 46	in alarm	174	open	274
Sensor 47	in alarm	175	open	275
Sensor 48	in alarm	176	open	276
Sensor 49	in alarm	177	open	277
Sensor 50	in alarm	178	open	278
Sensor 51	in alarm	179	open	279
Sensor 52	in alarm	180	open	280
Sensor 53	in alarm	181	open	281
Sensor 54	in alarm	182	open	282
Sensor 55	in alarm	183	open	283
Sensor 56	in alarm	184	open	284
Sensor 57	in alarm	185	open	285
Sensor 58	in alarm	186	open	286
Sensor 59	in alarm	187	open	287
Sensor 60	in alarm	188	open	288
Sensor 61	in alarm	189	open	289
Sensor 62	in alarm	190	open	290
Sensor 63	in alarm	191	open	291
Sensor 64	in alarm	192	open	292
Sensor 65	in alarm	193	open	293
Sensor 66	in alarm	194	open	294
Sensor 67	in alarm	195	open	295
Sensor 68	in alarm	196	open	296
Sensor 69	in alarm	197	open	297

**Table 8. Sensor Number Event Trigger Numbers**

Sensor Number	State	Trig-ger No.	State	Trig-ger No.
Sensor 70	in alarm	198	open	298
Sensor 71	in alarm	199	open	299
Sensor 72	in alarm	200	open	300
Sensor 73	in alarm	201	open	301
Sensor 74	in alarm	202	open	302
Sensor 75	in alarm	203	open	303
Sensor 76	in alarm	204	open	304

**Table 9. System Feature Event Trigger Numbers**

Feature	State	Trigger No.
Phone Test	in alarm	205
RF Touchpad Reports	in alarm	206
AC Failure	in alarm	207
CPU Low Battery	in alarm	208
Auto Phone Test	in alarm	209
Receiver Failure	in alarm	210
Back In Service	in alarm	211
Phone Failure	in alarm	212
Buffer Full	in alarm	213
System Tamper	in alarm	214
Freeze	in alarm	215
No Activity	in alarm	216
Fire Panic	in alarm	217
Police Panic	in alarm	218
Auxiliary Panic	in alarm	219
Opening Report	in alarm	220
Closing Report	in alarm	221
Latchkey Report	in alarm	222
Duress	in alarm	223
Force Armed Report	in alarm	224
Fire In Partition	in alarm	225

**Note**

When using event trigger numbers in Table 9, the corresponding feature must be turned on (enabled) to activate outputs.

**Table 10. Response Numbers\***

Siren Tracking	Trip Delay	Response Time	Response No.
no	no	momentary	00
no	no	3 minutes <sup>5</sup>	01
no	no	siren time <sup>2</sup>	02
no	no	sustained <sup>3</sup>	03
no	yes <sup>4</sup>	momentary	04
no	yes <sup>4</sup>	3 minutes <sup>5</sup>	05
no	yes <sup>4</sup>	siren time <sup>2</sup>	06
no	yes <sup>4</sup>	sustained <sup>3</sup>	07
yes <sup>1</sup>	no	momentary	08
yes <sup>1</sup>	no	3 minutes <sup>5</sup>	09
yes <sup>1</sup>	no	siren time <sup>2</sup>	10
yes <sup>1</sup>	no	sustained <sup>3</sup>	11
yes <sup>1</sup>	yes <sup>4</sup>	momentary	12
yes <sup>1</sup>	yes <sup>4</sup>	3 minutes <sup>5</sup>	13
yes <sup>1</sup>	yes <sup>4</sup>	siren time <sup>2</sup>	14
yes <sup>1</sup>	yes <sup>4</sup>	sustained <sup>3</sup>	15

**Notes for Table 10 Response Numbers**

1. If an event does not trigger sirens, siren tracking response numbers activate without turning on the output. If sirens are triggered by another event, the output pulses to match the siren.

If the siren cadence changes (for example from police to fire), outputs set up for siren tracking change to match the siren and all pulsing outputs pulse to one common cadence. However, HOM outputs won't be synchronized with panel or SnapCard outputs or the panel speaker output.

**Note**

The relay's mechanical lifetime may be exceeded if an output is set up for a siren tracking response and a pulsing siren (auxiliary or fire) is active for long time periods. A HOM or SnapCard relay output's lifetime expectancy is about 350 total pulsing hours.

2. If an event does not trigger sirens, siren time response times activate outputs only if sirens are active for another reason.
3. If an alarm event does not necessarily require disarming (no activity, closing report, etc.), outputs set up for a sustained response time remain activated until the next arming level change.
4. If an event occurs that activates an output set up for trip delay, the delay and output activation can be canceled by trigger event restoral.

**Note**

The trip delay is factory set for 30 seconds and cannot be changed.

5. Activated outputs set up for a 3-minute response time remain active for the entire 3 minutes. To deactivate the output before the 3-minute time expires, you must enter program mode or remove panel power.  
  
Activated outputs set up for a momentary or 3-minute response time restart if the same trigger event occurs again.

## Wireless Touchpads Menu

The *WIRELESS TOUCHPADS* menu lets you learn and delete wireless touchpads in the selected partition.

The following describes how to learn and delete wireless touchpads.

**Note**

A SuperBus RF Receiver must be installed to learn wireless touchpads into panel memory.

<b>Learn Touchpad</b> <span style="float: right;"><i>(Wireless Touchpads)</i></span> <b>(1200—partition 1, 1210—partition 2)</b>
<p>(Default = none) This menu lets you learn wireless touchpads into panel memory.</p> <p><b>To Learn Touchpads:</b></p> <ol style="list-style-type: none"> <li>1. With the display showing <i>WIRELESS TOUCHPADS</i>, press #. The display shows <i>PARTITION 1</i>.</li> <li>2. Press <b>A</b> or <b>B</b> to select the desired partition, then press #. The display shows <i>LEARN TOUCHPAD</i>.</li> <li>3. Press # and the display shows <i>TRIP TOUCHPAD nm</i>, where <i>nm</i> is the lowest available touchpad number 01 - 04.</li> <li>4. Press <b>A</b> or <b>B</b> to select 01, 02, 03, or 04, then press #.</li> <li>5. Press the <b>BYPASS</b> button on wall-mount and hand-held touchpads or the <b>LOCK</b> and <b>UNLOCK</b> buttons together on keychain touchpads. The display shows <i>TRIP TOUCHPAD nm</i>, where <i>nm</i> is the next available touchpad number.</li> <li>6. Repeat step 3 until all touchpads are learned.</li> </ol>
<b>Delete Touchpad</b> <span style="float: right;"><i>(Wireless Touchpads)</i></span> <b>(1201—partition 1, 1211—partition 2)</b>
<p>(Default = none) This menu lets you delete wireless touchpads from panel memory.</p> <p><b>To Delete Touchpads:</b></p> <ol style="list-style-type: none"> <li>1. With the display showing <i>WIRELESS TOUCHPADS</i>, press #. The display shows <i>PARTITION 1</i>.</li> <li>2. Press <b>A</b> or <b>B</b> to select the desired partition, then press #. The display shows <i>LEARN TOUCHPAD</i>.</li> <li>3. Press <b>B</b> and the display shows <i>DELETE TOUCHPAD</i>.</li> <li>4. Press # and the display shows <i>DELETE TOUCHPAD 01</i>.</li> <li>5. Press <b>A</b> or <b>B</b> to select 01, 02, 03, or 04, then press #. The display shows <i>DELETE TOUCHPAD nm DONE</i>.</li> </ol>

## Entering User Programming Mode

The user programming mode lets you program the following system settings:

- Regular User Codes
- Partition Master Codes
- System Master Code
- Time and Date
- Schedules
- Attach Schedules to Events
- Options
- View System Version Information
- Energy Saver Low and High Setpoints

You can enter user programming using the system master code or a partition master code. Regardless of which code is used, you will have access only to those settings for the specific partition.

For example:

- Partition 1 users can enter user programming with the system master or partition 1 master codes, but cannot access partition 2 settings.
- Partition 2 users can enter user programming with the system master or partition 2 master codes, but cannot access partition 1 settings.

The system master code default is 1234. Partition master code defaults are blank and must be programmed by first entering user programming with the system master code.

**To enter user-programming mode:**

Press 9 + C0DE (system or partition master code). The display shows *USER CODES*.

## User Codes Menu

The *USER CODES* menu lets you program user codes, partition master codes, and a system master code.

### Regular User Codes (User Codes) (00 thru 59)

(Default = none) Regular User Codes perform basic arming and disarming functions in their respective partition. The system (all partitions) allows up to 60 user codes (user numbers 00 - 59). This means if user number 02 is assigned a user code in partition 1, partition 2 users cannot view or assign a code to this user number.

User numbers that show \*\*\*\* indicate no code is currently programmed for that user number.

#### To program Regular User Codes:

1. With the display showing *USER CODES*, press # and the display shows *REGULAR USER CODES*.
2. Press # and the display shows *USER nn - nnnn* (first available user number and current code).
3. Enter a 4-digit user code or press **A** or **B** to select the desired user number and enter a 4-digit user code, then press #.  
The display flashes the entered code, then stops after pressing # and displays *USER nn - nnnn* (new code).

#### To delete Regular User Codes:

1. Using the appropriate partition master code, enter user programming in the partition where the user code to be deleted resides. The display shows *USER CODES*.
2. Press # and the display shows *REGULAR USER CODES*.
3. Press # and the display shows *USER nn - nnnn* (first available user number and current code).
4. Press **A** or **B** to select the desired user number/user code you want to delete.
5. Enter a 4-digit code that is the same as the partition master code used in step 1, then press #.  
The display flashes the entered code, then stops after pressing # and displays *USER nn - \*\*\*\** (no code).

### Partition Master Code (User Codes) (010—partition 1, 011—partition 2)

(Default = none) The Partition Master Code performs all partition and user programming functions in the specific partition.

#### To change a Partition Master Code:

1. With the display showing *USER CODES*, press #.  
The display shows *REGULAR USER CODES*.
2. Press **A** or **B** until the display shows *PARTITION MASTER CODE*.
3. Press # and the display shows *PARTITION nnnn* (current code).
4. Enter a new 4-digit partition master code, then press #.  
The display flashes the entered code, then stops after pressing # and displays *PARTITION nnnn* (new code).

#### To delete a Partition Master Code:

1. While in the specific partition, enter user programming with the system master code ( $\boxed{9}$  +  $\boxed{C}\boxed{O}\boxed{D}\boxed{E}$ ). The display shows *USER CODES*.
2. Press **A** or **B** until the display shows *PARTITION MASTER CODES*, then press #. The display shows *PARTITION nnnn* (current code).
3. Enter the 4-digit system master code, then press #.  
The display flashes the entered code, then stops after pressing # and displays *PARTITION \*\*\*\** (no code).

### System Master Code. (User Codes) (020)

(Default = 1234) The System Master Code performs all system functions in all partitions and in user programming.

### To change the System Master Code:

1. Enter user programming mode with the System Master CODE.
2. With the display showing *USER CODES*, press #. The display shows *REGULAR USER CODES*.
3. Press **A** or **B** until the display shows *SYSTEM MASTER CODE*.
4. Press # and the display shows *SYSTEM MASTER 1234* (or current code).
5. Enter a new 4-digit system master code, then press #.  
The display flashes the entered code, then stops after pressing # and displays *SYSTEM MASTER nnnn* (new code).

### Date (11) *(Time and Date)*

(Default = 01/01/98) This setting lets you adjust the panel's calendar to the correct month, day, and year.

### To set the Date:

1. With the display showing *TIME AND DATE*, press # then **B** and the display shows *DATE nn/nn/nn* (current date).
2. Enter the correct month (01 - 12), day (01 - 31), and year (00 - 99). For example, enter 090198 for September 1, 1998.
3. Press # and the display shows *PARTITION nnnn* (current code).

## Time and Date Menu

The *TIME AND DATE* menu lets you set the panel's clock and calendar. Alphanumeric touchpads display the time and date whenever the system is disarmed. Setting the time and date is important for accurate tracking of system events stored in the event buffer. The panel uses a global clock and calendar for time and date.

The following describes how to set the panel's time and date.

### Time (10) *(Time and Date)*

(Default = 00:00) This setting lets you adjust the panel's clock to the correct time. The panel uses a 24-hour clock, eliminating the need to designate am or pm. For example, to set the time to 4:17pm, enter 1617.

### To set the Time:

1. With the display showing *TIME AND DATE*, press # and the display shows *TIME hh:mm AM/PM* (current time).
2. Enter the correct time (0000 - 2359), then press #.  
The display flashes the entered time, then stops after pressing # and displays *TIME nn:nn AM/PM* (new time).

## Set Up Schedules Menu

The *SET UP SCHEDULES* menu lets you set up time frames for any day in the week for light control, latch-key opening/closing, and notify by exception opening/closing. The system (all partitions) allows you to set up to 16 schedules (00 - 15).

Setting up schedules consists of setting a start and stop time for each schedule, then selecting which days of the week the schedule is active. You can also set up a *rollover* schedule that starts one day and ends on the next or another day. This saves programming time and leaves more schedules available in case they are needed later.

**Rollover Schedules:** To set up a schedule to rollover from Tuesday evening to Wednesday morning, set a schedule start time for 10:00 pm and a stop time for 5:00 am. Set the schedule to turn on Tuesday. Because the stop time is set for morning, the system automatically carries the schedule over to the next day.

Using the same start and stop times described above, set the schedule to turn on Monday through Friday. Now, one schedule covers the entire week.

If you are programming schedules for your customer, be sure to record the settings in *Appendix A: User Sheets* in the *User's Guide*.



**Set Up Schedules**

**2XXY where XX = schedule 00 thru 15 and Y = start/stop 0 thru 8—monday thru sunday)**

(Default = 00:00) This menu lets you set up start/stop times for each day of the week. The panel uses a 24-hour clock, eliminating the need to designate am or pm.

**To set up a Time Schedule:**

1. Enter user programming with the system or appropriate partition master code. The display shows *USER CODES*.
2. Press **A** or **B** until the display shows *SET UP SCHEDULES*.
3. Press **#** and the display shows *SCHEDULE 00*. If you want a different schedule number, press **A** or **B** until the desired schedule number appears.
4. Press **#** and the display shows *START TIME hh:mm AM/PM (current setting)*.
5. Enter the desired starting time (00:00 - 23:59), then press **#**.  
The display flashes the entered time, then stops after pressing **#** and displays *START TIME hh:mm AM/PM (new setting)*.
6. Press **B** and the display shows *STOP TIME hh:mm AM/PM (current setting)*.
7. Enter the desired stop time (00:00 - 23:59), then press **#**.  
The display flashes the entered time, then stops after pressing **#** and displays *STOP TIME hh:mm AM/PM (new setting)*.
8. Press **B** and the display shows *MONDAY OFF/ON (current setting)*. To select a different day, continue pressing **B** until the desired day appears.
9. Press 1 (off) or 2 (on) then press **#**.  
The display flashes the entered selection, then stops after pressing **#** and displays *the new setting for the selected day*.
10. Repeat steps 8 and 9 until all desired settings for each day are set.

## Attach Schedules to Events Menu

---

The *ATTACH SCHEDULES TO EVENTS* menu lets you link the following system events to time schedules:

- Latchkey Opening—sends a report if system is disarmed within the attached time schedule
- Latchkey Closing—sends a report if system is armed within the attached time schedule.
- Exception Opening—sends a report if system is not disarmed within the attached time schedule.
- Exception Closing—sends a report if system is not armed within the attached time schedule.
- Light (1 - 9)—X-10 controlled lights are activated by the attached time schedule.

**Attach Schedules To Events**

**(3XXYY where XX = events 00 thru 12 and YY = schedule 00 thru 15)**

(Default = off) This setting lets you attach a specific event to a time schedule. The following events can be attached to any time schedule:

Latchkey Opening  
 Latchkey Closing  
 Exception Opening  
 Exception Closing  
 Lights 1 thru 9

**To Attach Schedules to Events:**

1. Enter user programming with the system or appropriate partition master code. The display shows *USER CODES*.
2. Press **A** or **B** until the display shows *ATTACH SCHEDULES TO EVENTS*.
3. Press **#** and the display shows *LATCHKEY OPENING*. If you want a different event, press **A** or **B** until the desired event appears.
4. Press **#** and the display shows *SCHEDULE 00 OFF/ON (current setting)*. If you want a different schedule, press **A** or **B** until the desired schedule appears.
5. Press 1 (OFF) or 2 (ON), then press **#**.  
The display flashes the entered selection, then stops after pressing **#** and displays *the new setting for the selected schedule*.
6. Repeat steps 3, 4, and 5 until all desired events are attached to schedules.

## Options Menu

The *OPTIONS* menu lets you set up the system for downloading, silent arming, and adjust alphanumeric touchpad display brightness.

<b>Downloading</b> (40)	<i>(Options)</i>
<p>(Default = on) This setting determines whether the panel can communicate with ITI ToolBox software for programming the system from off-site.</p> <p><b>Note</b> The panel must have a Downloader phone number and Downloader code programmed and be connected to a phone line for this feature to work.</p> <p><b>To turn Downloading off or on:</b></p> <ol style="list-style-type: none"> <li>1. Enter user programming with the system or appropriate partition master code. The display shows <i>USER CODES</i>.</li> <li>2. Press <b>A</b> or <b>B</b> until the display shows <i>OPTIONS</i>.</li> <li>3. Press # and the display shows <i>DOWNLOADING OFF/ON (current setting)</i>.</li> <li>4. Press <b>1</b> (off) or <b>2</b> (on) then press #. The display flashes the entered selection, then stops after pressing # and displays <i>DOWNLOADING OFF/ON (new setting)</i>.</li> </ol>	
<b>Silent Arming</b> (41)	<i>(Options)</i>
<p>(Default = off) This setting determines whether the partition arms the system with (off) or without (on) sounding status beeps from sirens and the touchpad.</p> <p><b>Note</b> Turning this feature on means the user never has to press 5 (SILENT) before arming the system in order to silence status sounds.</p> <p><b>To turn Silent Arming off or on:</b></p> <ol style="list-style-type: none"> <li>1. Enter user programming mode with the system or appropriate partition master code. The display shows <i>USER CODES</i>.</li> <li>2. Press <b>A</b> or <b>B</b> until the display shows <i>OPTIONS</i>.</li> <li>3. Press #, then <b>B</b> and the display shows <i>SILENT ARMING OFF/ON (current setting)</i>.</li> <li>4. Press <b>1</b> (off) or <b>2</b> (on) then press #. The display flashes the entered selection, then stops after pressing # and displays <i>SILENT ARMING OFF/ON (new setting)</i>.</li> </ol>	

<b>Touchpad Brightness</b> (42)	<i>(Options)</i>
<p>(Default = 2) This setting lightens or darkens the background on alphanumeric touchpad displays. Each touchpad display can be set independently to compensate for lighting conditions in the touchpad location.</p> <p><b>To adjust Touchpad Brightness:</b></p> <ol style="list-style-type: none"> <li>1. Enter user programming mode with the system or appropriate partition master code. The display shows <i>USER CODES</i>.</li> <li>2. Press <b>A</b> or <b>B</b> until the display shows <i>OPTIONS</i>.</li> <li>3. Press #, then <b>B</b> twice and the display shows <i>TOUCHPAD BRIGHTNESS n (current setting)</i>.</li> <li>4. Enter a setting from <b>0</b> (darkest background) to <b>3</b> (brightest background) then press #. The display flashes the entered selection, then stops after pressing # and displays <i>TOUCHPAD BRIGHTNESS n (new setting)</i>.</li> </ol>	
<b>Volume</b> (43)	<i>(Options)</i>
<p>(Default = 4) This setting determines the volume level of status sounds from speakers connected to the Phone Interface/Voice Module.</p> <p><b>Note</b> This menu appears <i>only</i> if a Phone Interface/Voice Module is connected to the panel.</p> <p><b>To adjust status sound Volume:</b></p> <ol style="list-style-type: none"> <li>1. Enter user programming mode with the system or appropriate partition master code. The display shows <i>USER CODES</i>.</li> <li>2. Press <b>A</b> or <b>B</b> until the display shows <i>OPTIONS</i>, then press #. The display shows <i>DOWNLOADING OFF/ON</i>.</li> <li>3. Press <b>A</b> or <b>B</b> until the display shows <i>VOLUME n (current setting)</i>.</li> <li>4. Enter a setting from <b>0</b> (off) to <b>7</b> (loudest) then press #. The display flashes the entered selection, then stops after pressing # and displays <i>VOLUME n (new setting)</i>.</li> </ol>	

**Voice Chime  
(44)***(Options)*

(Default = off) This setting determines whether speakers connected to the Phone Interface/Voice Module announce perimeter sensor/zone numbers that are tripped when the Chime feature is on. For example, "Sensor one open."

**Note**

This menu appears *only* if a Phone Interface/Voice Module is connected to the panel.

**To turn Voice Chime off or on:**

1. Enter user programming mode with the system or appropriate partition master code. The display shows *USER CODES*.
2. Press **A** or **B** until the display shows *OPTIONS*, then press **#**. The display shows *DOWNLOADING OFF/ON*.
3. Press **A** or **B** until the display shows *VOICE CHIME OFF/ON (current setting)*.
4. Press **1** (off) or **2** (on) then press **#**. The display flashes the entered selection, then stops after pressing **#** and displays *VOICE CHIME OFF/ON (new setting)*.

**System Version Menu**

The *SYSTEM VERSION* menu lets you view and identify panel hardware and software. This information is primarily used for troubleshooting purposes.

**System Version**

**(50 = factory code, 51 = system number, 52 = system level)**

(Default = N/A) This menu lets you view and identify panel hardware and software.

**To view and identify the System Version:**

1. Enter user programming with the system or appropriate partition master code. The display shows *USER CODES*.
2. Press **A** or **B** until the display shows *SYSTEM VERSION*.
3. Press **#** and the display shows *FACTORY CODE nnn\*nnnn*.
4. Press **B** and the display shows *SYSTEM NUMBER \*nnnnnnn*.
5. Press **B** again and the display shows *SYSTEM LEVEL nnnn*.

## Energy Saver Menu

---

The *ENERGY SAVER* menu lets you set the energy saver module low- and high-setpoints. These setpoints determine when the module's relay closes, thereby completing the circuit through the thermostat to the furnace/air-conditioner.

<b>Low Setpoint</b> <b>(60)</b>	<i>(Energy Saver)</i>
<p>(Default = 50°F) This setting determines the temperature at which the energy saver module relay closes to activate the furnace.</p>	
<p><b>Note</b> The low setpoint cannot be set higher than the high setpoint.</p>	
<p><b>To set the Low Setpoint:</b></p> <ol style="list-style-type: none"><li>1. With the display showing <i>ENERGY SAVER</i>, press # and the display shows <i>LOW SETPOINT nn DEGREES (current setting)</i>.</li><li>2. Enter the desired 2-digit temperature (45 - 90), then press #. The display flashes the entered selection, then stops after pressing # and displays <i>LOW SETPOINT nn DEGREES (new setting)</i>.</li></ol>	
<b>High Setpoint</b> <b>(61)</b>	<i>(Energy Saver)</i>
<p>(Default = 90°F) This setting determines the temperature at which the energy saver module relay closes to activate the air-conditioner.</p>	
<p><b>Note</b> The high setpoint cannot be set lower than the low setpoint.</p>	
<p><b>To set the High Setpoint:</b></p> <ol style="list-style-type: none"><li>1. With the display showing <i>ENERGY SAVER</i>, press # then <b>B</b> once and the display shows <i>HIGH SETPOINT nn DEGREES (current setting)</i>.</li><li>2. Enter the desired 2-digit temperature (45 - 90), then press #. The display flashes the entered selection, then stops after pressing # and displays <i>HIGH SETPOINT nn DEGREES (new setting)</i>.</li></ol>	

## Testing the System

This section describes the following:

- Basic System Commands
- Testing Zones/Sensors

You should test the system after installing, servicing, and after adding or removing devices from the system. Refer to the “Troubleshooting” section if correct test results are not achieved.

### Basic System Commands

Table 11 describes the system’s basic touchpad operating commands. Table 12 describes the system’s basic touchtone phone operating commands (for systems with a Phone Interface/Voice Module). For complete details on system operation, including user programming, refer to the system’s owner’s manual.

**Table 11. Basic Touchpad Commands**

Command	System Response
* (STATUS)	Indicates system’s current status
1 + CODE	Disarms partition to OFF
2 + CODE	Arms partition to STAY
3 + CODE	Arms partition to AWAY
2 (quick arm on)	Arms partition to STAY
3 (quick arm on)	Arms partition to AWAY
2 or 3 + CODE + 4 or 2 or 3 + 4	Makes partition entry/exit doors instant (4 must be pressed within five seconds of arming)
5 + 2 or 3 + CODE or 5 + 2 or 3	Arms partition silently (no arming status beeps)
2 or 3 + CODE + 6 or 2 or 3 + 6	Arms partition with Latchkey feature enabled
7 + 1	Turns chime feature on and off
7 + 2	Turns energy saver on and off
7 + 6	Identifies alarms in memory
8 + CODE + 2	Initiates a phone test
8 + CODE + 3	Initiates a sensor test
8 + installer CODE + 3	Initiates a dealer sensor test
0 + 0	Turns all lights on and off
0 + n (1 thru 9)	Turns selected light on and off

**Table 12. Basic Touchtone Phone Commands**

Command	System Response
# + * + *	Indicates system’s current status
# + 1 + CODE	Disarms partition to OFF
# + 2 + CODE	Arms partition to STAY
# + 3 + CODE	Arms partition to AWAY
# + 2 (quick arm on)	Arms partition to STAY
# + 3 (quick arm on)	Arms partition to AWAY
# + 2 or 3 + CODE + 4 or # + 2 or 3 + 4	Makes partition entry/exit doors instant (4 must be pressed within five seconds of arming)
# + 5 + 2 or 3 + CODE or # + 5 + 2 or 3	Arms partition silently (no arming status beeps)
# + 2 or 3 + CODE + 6 or # + 2 or 3 + 6	Arms partition with Latchkey feature enabled
# + 7 + 1	Turns chime feature on and off
# + 7 + 2	Turns energy saver on and off
# + 7 + 3	Disables system access from on-site phones
# + 7 + 6	Identifies alarms in memory
# + 8 + CODE + 2	Initiates a phone test
# + 8 + CODE + 3	Initiates a sensor test
# + 8 + installer CODE + 3	Initiates a dealer sensor test
# + 0 + 0	Turns all lights on and off
# + 0 + n (1 thru 9)	Turns selected light on and off

## Testing Zones/Sensors

---

We recommend that you test zones/sensors after all programming is completed and whenever a zone/sensor-related problem occurs.

If the system does not respond as described in the following procedure, see the “Troubleshooting” section.

### Note

While the sensor test is a valuable installation and service tool, it only tests sensor operation for the current conditions. You should perform a sensor test after any change in environment, equipment, or programming.

1. Place all zones/sensors in their secured (non-alarm) state.
2. At an alphanumeric touchpad, enter the sensor test mode by pressing **8 + installer CODE + 3**. The touchpad sounds one beep and displays *SENSOR TEST*.  
The system stays in sensor test for 15 minutes. After 15 minutes the panel disarms to *OFF*, automatically.
3. Trip each zone/sensor one at a time. Touchpads (and Supervised Wireless Sirens) should sound one short, high-pitched beep and the display shows the sensor name (or number if text for that sensor is not programmed) and *OK*.

### Note

If you hear a long, low-pitched beep, proceed to the following section “If a Zone/Sensor Does Not Test.”

4. Press the **STATUS** button when you think all zones/sensors are tested. The touchpad displays any untested zones/sensors and touchpad panics. If all zones/sensors and touchpad panics have been tested, the display shows *SENSOR TEST OK*.
5. Test any untested zones/sensors and touchpad panics.
6. If you need more time to complete the sensor test, press **8 + installer CODE + 3** while the system is still in sensor test. This adds another 15 minutes of test time.
7. When all zones/sensors and touchpad panics have been tested, press **1 + installer CODE** to exit sensor test.

## If a Zone/Sensor Does Not Test

---

If touchpads and sirens sound a long, low-pitched beep when a zone/sensor is tripped, this indicates the sensor’s signal strength is below acceptable limits. Distance from the receiver and/or installation environment are most likely affecting the sensor’s signal strength.

When possible, locate wireless sensors within 100 feet of the panel. While a transmitter may have a range of 1,000 feet or more out in the open, the environment at the installation site can have a significant effect on transmitter range. Refer to the “Troubleshooting” section to resolve the problem.

### To increase system wireless sensor range:

- Relocate the SuperBus RF Receiver
- Install a Learn Mode Sensor Repeater

For wireless sensors that don’t respond, use an ITI RF Sniffer (60-401) test tool to verify that the sensor is transmitting. Constant beeps from the RF Sniffer indicate a runaway (faulty) sensor. Remove the sensor’s battery and replace the sensor.

## Testing Phone Communication

---

Perform a phone test to check the phone communication between the panel and the central monitoring station.

### To perform a phone test:

1. Contact the central monitoring station to inform them that you are testing the system.
2. Press **8+system or partition master CODE + 2**. The display reads *PHONE TEST* and the touchpad sounds one beep.  
When the panel completes the test, the system returns to the previous arming level, automatically.

If the display continues to show *PHONE TEST* for 1½ minutes or more, enter **1+system or partition master CODE** and refer to the “Troubleshooting” section.

## Testing Central Station/Pager Communication

After performing sensor and phone tests, check that the system is reporting alarms successfully to the central station.

### To test communication with the central station/pager:

1. Call the central station and tell the operator that you will be testing the system.
2. Arm the system.
3. Test each of the touchpad and wireless panic buttons and trip at least one sensor of each type (fire, intrusion, etc.) to verify correct operation.
4. If an Interrogator is installed, verify that it is operating correctly and that the central station operator can listen-in and talk-back through it.
5. Check pager displays to verify reports are received.

Pagers display an event code, sensor number, and account number. For example, a pager display of *999-0255789* indicates the following:

999=alarm condition, 02=sensor number in alarm, 56789=partition account number.

If the streamlining feature is on, the account number is not displayed.

Table 10 describes the pager event codes.

**Table 13. Pager Event Code Descriptions**

Code	System Event
111	System has been disarmed
222	System has been armed to STAY
333	System has been armed to AWAY
118	Trouble condition has been cleared
119	Alarm has been canceled
555	Phone test
888	System has a trouble condition
999	System is in alarm

6. When you finish testing the system, call the central monitoring station to verify that the alarms were received.

## Testing Outputs

All outputs (onboard, SnapCard, and HOM) should be tested to verify configuration programming.

### Caution

Be sure to contact the central monitoring station *before* activating outputs that trigger from an alarm condition.

### To test outputs:

1. Verify that all wiring at the panel and output devices is correct.
2. Activate each programmed system triggering event to verify correct output response.

## Testing Light Control

Test all lights plugged into X-10 Lamp Modules to verify house code and light number settings.

### To test light control:

1. Press **0 + 0** repeatedly to turn all lights on and off together.
2. Press **0 + 1** repeatedly to turn light 1 on and off.
3. Repeat step 2 for remaining lights (**0 + 2** for light 2, **0 + 3** for light 3, etc.).
4. Arm the system to **Away**. All lights plugged into modules set to Unit 1 should turn on and stay on for 5 minutes. All lights plugged into modules set to Unit 2 should blink three times to indicate the arming level. Remaining lights are unaffected.
5. Disarm the system. If Unit 1 lights were on for an entry or alarm, they will turn off in 5 minutes. Unit 2 lights should blink once to indicate the system is off. Remaining lights are unaffected.
6. All lights should turn on and remain on during fire and auxiliary/medical alarms and flash during a police or an intrusion alarm.

## Testing the Energy Saver Module

---

Test the Energy Saver Module to verify it overrides the thermostat.

### Note

The system must have high- and low-temperature limits set to test the Energy Saver Module.

### To test the Energy Saver Module:

1. Press **STATUS + STATUS** to display the system status, *ENERGY SAVER OFF*, and the present *TEMPERATURE nn°*. The temperature displayed (and/or announced) should match the house thermostat. If the temperatures do not match, refer to the *ACCESSORY MODULES—BUS DEVICES* menu in the “Programming” section.
2. Press **7 + 2** to turn on the ESM. The display shows *ENERGY SAVER ON* and the ESM relay will click once.
3. Press **7 + 2** again to turn the ESM off. The display shows *ENERGY SAVER OFF*.

### Note

There is a 5-minute delay after the Energy Saver Module returns control to the furnace/AC before it will override the furnace/AC again.

If the red ESM LED is not flashing continuously, remove panel AC and backup battery power. Verify that all wiring is correct and that all bus devices (including hardwire touchpads) are set with different unit numbers.

Whenever the ESM unit number is changed, you must remove and restore panel power, then enter the program mode so the panel and ESM communicate successfully.

## Downloader Programming

---

The panel can be programmed remotely using ToolBox. Use the information you recorded in Appendix A to inform the downloading operator of your installation’s programming requirements.

## ToolBox Downloader Programming

---

### Note

A Downloader Phone Number must be programmed and user-programmable option Downloading must be set to on in order for remote downloader programming to work.

### To initiate a ToolBox download session:

1. Contact your download station and ask the operator to prepare to download to the panel.
2. Make sure the system is disarmed.
3. Press **8 + system or partition master CODE + 7 + 0** (any), **1** (up), or **2** (down).  
The display shows *SYSTEM DOWNLOAD* during the downloading process.

If the alphanumeric touchpad does not display *SYSTEM DOWNLOAD*, call the downloader operator to verify the downloader phone number and that ToolBox is set up properly. Refer to the “Troubleshooting” section if the problem persists.



# Troubleshooting

---

This section describes what to do if you experience problems with system operation. Topics are divided into separate tables for easy reference.

- Table T1: Panel Power
- Table T2: Access Codes
- Table T3: Arming and Disarming
- Table T4: Bypassing
- Table T5: Wireless Sensor and Touchpad Batteries
- Table T6: Central Station/Pager Reporting
- Table T7: Alphanumeric Touchpads
- Table T9: LED Touchpads
- Table T10: Piezo Sirens
- Table T11: Supervised Wireless Sirens
- Table T12: Hardwire Zones
- Table T13: Wireless Sensor Zones
- Table T14: Wireless Touchpads
- Table T15: Phones
- Table T16: Light Control

## Panel Power

**Table T1: Panel Power Troubleshooting**

Problem	Action/Solution
<p>Panel does not power up. Touchpads don't display or respond.</p>	<ol style="list-style-type: none"> <li>1. Check that panel transformer is plugged into an unswitched outlet.</li> <li>2. Check the AC circuit breaker to be sure the circuit is live.</li> <li>3. Check that the backup battery is installed correctly and the AC power transformer is plugged in.</li> <li>4. Check for proper panel and transformer wiring.</li> <li>5. Measure the incoming AC voltage at panel terminals 1 and 2. It should read 24 VAC.</li> </ol>
<p>No incoming AC voltage at panel terminals 1 and 2.</p>	<ol style="list-style-type: none"> <li>1. Unplug the AC power transformer and disconnect the wires from the transformer and the panel.</li> <li>2. Check transformer to panel wire for short or open circuits.</li> <li>3. Plug in the transformer and check for 24 VAC at the transformer unconnected terminals. If zero (0) volts, replace the transformer.</li> </ol>
<p>Touchpad display indicates <i>System Low Battery</i> or voice sounds "<i>System low battery.</i>"</p>	<ol style="list-style-type: none"> <li>1. Check that the backup battery is installed correctly and the AC power transformer is plugged in.</li> <li>2. Measure the incoming AC voltage at the panel terminals 1 and 2. It should read 24 VAC.</li> <li>3. Remove the backup battery power by disconnecting the battery's red (positive) wire. Check for 11.75 to 13.5 VDC battery charging voltage between panel terminal 3 (GND) and the disconnected red battery wire. If the charging voltage is <b>not</b> within range, call Technical Services.</li> <li>5. Check for 11.75 to 13.5 VDC battery voltage between the backup battery's spade lugs. If the battery voltage is <b>not</b> within this range, replace the battery.</li> </ol> <p><b>Note</b> When the panel is running a backup battery test, the reading at the connected battery can range from 11.2 to 13.5 VDC. The panel automatically runs a backup battery test under the following conditions: (1) on initial power-up, (2) during user sensor test, (3) once every minute when backup battery has failed, (4) once every 24 hours at the programmed STIME (UL 98 Options off) or once every 4 hours (UL 98 Options on).</p> <p><b>Note</b> With the AC power transformer plugged in, the panel automatically charges the battery. While the battery is charging for the first time it is normal for the system to indicate <i>System battery failure</i>. This can take a number of hours depending on the battery's initial charge. Once the battery reaches 12.5 VDC (full charge as measured while in battery test), the condition clears. If the trouble condition persists after 24 hours, replace the backup battery.</p>

**Table T1: Panel Power Troubleshooting (cont.)**

Problem	Action/Solution
<p>After pressing <b>STATUS</b> the touchpad indicates <i>AC Power Failure</i>. (Panel continues to operate from backup battery.)</p>	<ol style="list-style-type: none"> <li>1. Check the AC circuit breaker to be sure the circuit is live.</li> <li>2. Check for proper panel and transformer wiring.</li> <li>3. Check that the transformer is plugged into a nonswitched outlet and secured with the provided screw.</li> <li>4. Check that the transformer is supplying AC to the panel. (Transformer internal fuse may be blown.)</li> </ol> <p><b>WARNING!</b> Be careful when securing the transformer to an outlet with a metal cover. Hold the cover tightly in place. You could receive a serious shock if the metal outlet cover drops down onto the prongs of the plug while you are securing the transformer and cover to the outlet box.</p>

## Access Codes

---

**Table T2: Access Code Troubleshooting**

Problem	Action/Solution
<p>Customer cannot remember access code(s).</p>	<ol style="list-style-type: none"> <li>1. Check your records to see if you have the customer's access code(s) on file.</li> <li>2. Verify the access code(s) using the Downloader.</li> <li>3. Clear memory and reprogram the panel locally.</li> </ol>
<p>Installer cannot remember install code.</p>	<ol style="list-style-type: none"> <li>1. Check your records to see if you have the install code on file.</li> <li>2. Verify the install code using the Downloader.</li> <li>3. Use the Dealer Code to enter program mode and view the installer code.</li> <li>4. Call Technical Support for assistance.</li> </ol>
<p>Installer cannot remember dealer code</p>	<ol style="list-style-type: none"> <li>1. Check your records to see if you have the dealer code on file.</li> <li>2. Verify the dealer code using the Downloader.</li> <li>3. Call Technical Support for assistance.</li> </ol>

## Arming and Disarming

---

**Table T3: Arming/Disarming Troubleshooting**

Problem	Action/Solution
<p>System protests and won't arm.</p> <p>System won't disarm.</p>	<ol style="list-style-type: none"> <li>1. If arming to level 2, make sure all monitored perimeter doors and windows are closed.</li> <li>2. If arming to level 3, make sure all perimeter and interior sensors are closed.</li> <li>3. Press <b>STATUS</b> for an indication of the problem.</li> </ol> <ol style="list-style-type: none"> <li>1. Disarming using incorrect code. Enter correct code.</li> <li>2. Access code is not programmed or set up in user programming to disarm system.</li> <li>3. Wireless touchpad is not learned into system or hardwire touchpad is not communicating to panel. Check installer programming for learned wireless touchpads and check unit number (device address) of hardwire touchpads to make sure they are different from other bus devices.</li> <li>4. The entered code is not valid for the partition.</li> <li>5. The installer code is being used to disarm the system. The system is designed <i>not to disarm</i> using the installer code. Use a regular or partition master code to disarm the system.</li> </ol>

## Bypassing

---

**Table T4: Bypassing Troubleshooting**

Problem	Action/Solution
<p>Touchpad indicates <i>Invalid</i> and/or "<i>Invalid</i>" is heard when you attempt to bypass a sensor.</p> <p>System cancels sensor bypass when you try to arm to level 2 or 3.</p>	<ol style="list-style-type: none"> <li>1. Sensor is already bypassed.</li> <li>2. Attempting to bypass a 24-hour sensor that cannot be bypassed (group 26 fire sensors).</li> <li>3. Sensor is not active in the current arming level.</li> </ol> <ol style="list-style-type: none"> <li>1. Sensor is being bypassed before arming to 2—STAY or 3—AWAY. Arm to the desired level before bypassing a sensor.</li> </ol>

## Wireless Sensor and Touchpad Batteries

---

**Table T5: Wireless Sensor/Touchpad Battery Troubleshooting**

Problem	Action/Solution
System indicates <i>Sensor nn low battery</i> .	<p>1. Replace the indicated sensor's battery. Test the sensor/touchpad after replacing the battery.</p> <p><b>Note</b> If the sensor/touchpad is not tested after battery replacement, the system continues to show a low battery condition, since that was the last signal it received from the device. Testing the sensor/touchpad with new batteries allows the panel to receive a signal with good battery information.</p>

## Central Station/Pager Reporting

---

**Table T6: Reporting Troubleshooting**

Problem	Action/Solution
Central station/pager is not receiving reports.	<ol style="list-style-type: none"> <li>1. Check that the premises phone line is working.</li> <li>2. Perform a phone test.</li> <li>3. Check that the DB-8 cord is plugged into the RJ-31X/CA-38A jack.</li> <li>4. Check that the DB-8 cord is wired correctly to the panel.</li> <li>5. Check for correct phone line wiring between the TELCO block and RJ-31X/CA-38A jack.</li> <li>6. Replace faulty RJ-31X/CA-38A jack.</li> <li>7. Replace faulty DB-8 cord.</li> <li>8. Check for correct Phone Interface/Voice module wiring.</li> <li>9. Verify that central station/pager phone number is programmed into the panel. Reprogram the phone number and retest, if necessary.</li> <li>10. Verify that the correct phone format (SIA or CID) is being used.</li> <li>11. For pagers, extend the pager delay setting (see the <i>PHONE OPTIONS—GLOBAL</i> menu in the "Programming" section).</li> </ol>

## Alphanumeric Touchpads

---

**Table T7: Alphanumeric Touchpad Troubleshooting**

Problem	Action/Solution
Display shows all *****.	<ol style="list-style-type: none"> <li>1. Touchpad has the same device address as another bus device. Enter installer programming mode from a working touchpad to view device addresses of each bus device. Change the device address of the touchpad or the other bus device.</li> <li>2. Touchpad is not connected to panel bus terminals or is wired incorrectly. Check and correct wiring.</li> </ol>
Display is blank.	<ol style="list-style-type: none"> <li>1. Check that panel is powered up.</li> <li>2. Check for touchpad power and/or bus miswiring, opens, or shorts.</li> <li>3. Check touchpad brightness setting (see the user-programming <i>OPTIONS</i> menu in the “Programming” section).</li> </ol>
Touchpad buttons don’t beep when pressed.	<ol style="list-style-type: none"> <li>1. Check for touchpad power and/or bus miswiring, opens, or shorts.</li> <li>2. Check that key beeps option is set to on (see the <i>ACCESSORY MODULES—BUS DEVICES</i> menu in the “Programming” section).</li> </ol>

## LED Touchpads

---

**Table T8: LED Touchpad Troubleshooting**

Problem	Action/Solution
Touchpad does not power up (no LEDs turn on and buttons don’t beep when pressed).	<ol style="list-style-type: none"> <li>1. Check that panel battery is connected correctly and that panel transformer is plugged into an outlet that is not controlled by a switch.</li> <li>2. Check for correct wiring at touchpad and panel terminals.</li> <li>3. Check touchpad wiring for open or short condition.</li> </ol>
No LEDs turn on but beeps sound when buttons are pressed.	<ol style="list-style-type: none"> <li>1. Check for correct bus wiring connections (green and white wires) at touchpad and panel terminals.</li> <li>2. Make sure touchpad device address switches are set to a different number than all other bus devices. Change if necessary.</li> </ol>
Touchpad TROUBLE LED is flashing and system does not respond to commands from touchpad.	<ol style="list-style-type: none"> <li>1. Check for correct bus wiring connections (green and white wires) at touchpad and panel terminals.</li> <li>2. Make sure touchpad device address switches are set to a different number than all other bus devices. Change if necessary.</li> </ol>

## Speakers

---

**Table T9: Speaker Troubleshooting**

Problem	Action/Solution
Speakers don't sound alarms.	<ol style="list-style-type: none"> <li>1. Check for correct wiring at speaker and panel terminals; correct where necessary.</li> <li>2. Speaker output has shut down because panel detected terminal 7 or 8 is shorted to ground. Disconnect panel AC and battery backup power. Locate short and correct. Apply panel AC and backup battery power and retest.</li> <li>3. Alarm is in partition 2 and speaker is connected to panel terminals 7 and 8, which activate only for partition 1 alarms.</li> </ol>

## Piezo Sirens

---

**Table T10: Hardwire Siren Troubleshooting**

Problem	Action/Solution
Piezo sirens connected to HOM, Snap Card, or onboard (panel) outputs 1 and/or 2 don't produce any alarm sounds.	<ol style="list-style-type: none"> <li>1. Check for incorrect wiring between siren and panel; correct where necessary.</li> <li>2. Output has not been configured (set up) to activate sirens. Enter program mode and configure output (see <i>ACCESSORY MODULES—BUS DEVICES—HOM</i> or <i>SNAP CARD</i>, or <i>ONBOARD OPTIONS—OUTPUT 1, 2</i> in the “Programming” section).</li> </ol>

## Supervised Wireless Sirens

---

**Table T11: Supervised Wireless Siren Troubleshooting**

Problem	Action/Solution
<p>Sirens don't produce any sounds and LED doesn't respond.</p> <p>Siren works intermittently.</p>	<ol style="list-style-type: none"> <li>1. Check to make sure siren is not plugged into an outlet controlled by a switch. Move siren to a nonswitched outlet location and test.</li> <li>2. Panel doesn't have a Power Line Carrier (PLC) card installed. Install PLC card.</li> <li>3. Panel is not powered by a power line carrier transformer. Replace existing transformer with a power line carrier transformer.</li> <li>4. Power transformer and sirens are not plugged into outlets on the same electrical phase. Relocate sirens at different outlets to determine working locations.</li> <li>5. Siren is programmed with incorrect partition house code. Clear siren house code by pressing and holding siren button for 30 seconds. Reprogram with correct partition house code and retest.</li> <li>6. Siren house code is not programmed into panel. Enter program mode and set SWS and partition house codes.</li> </ol> <ol style="list-style-type: none"> <li>1. Check that siren and/or panel transformer is not plugged into an outlet shared with a major appliance, television, or computer which may generate noise and degrade the line carrier signal.</li> </ol>

## Hardwire Zones

---

**Table T12: Hardwire Zone Troubleshooting**

Problem	Action/Solution
<p>System doesn't go into alarm when zone is tripped.</p> <p>Zone reports trouble condition.</p>	<ol style="list-style-type: none"> <li>1. System is disarmed. Arm system and then trip the zone.</li> <li>2. Zone is not learned into panel memory. Enter installer/dealer program mode—LEARN SENSORS, and learn zone into memory.</li> <li>3. Zone is learned into wrong partition. Delete zone and learn into correct partition.</li> <li>4. For HIM zones, check that the HIM LED is blinking to verify communication with the panel. If LED is off, check wiring between HIM and panel.</li> </ol> <ol style="list-style-type: none"> <li>1. Check that onboard and Snap Card zone inputs have a 2k-ohm EOL resistor installed at the last device on the loop (4.7k-ohm for HIMs)—in series for N/C loops, in parallel for N/O loops.</li> <li>2. Check for zone wire fault—short circuit on N/C loops, open circuit on N/O loops.</li> <li>3. Make sure all devices on zone are in non-alarm state, then enter disarm command to reset zone.</li> </ol>



## Wireless Sensor Zones

**Table T13: Wireless Sensor Zone Troubleshooting**

Problem	Action/Solution
System doesn't respond (in sensor test or when armed) when sensor is tripped.	<ol style="list-style-type: none"> <li>1. Verify that receiver antennas are installed and connections are secure.</li> <li>2. Check that the wireless sensor battery is installed.</li> <li>3. Check the sensor battery for low voltage. Replace batteries, if necessary.</li> <li>4. Use an RF Sniffer (60-401) to verify that sensor is transmitting.</li> <li>5. Sensor is not learned into panel memory. Enter installer/dealer program mode—LEARN SENSORS, and learn sensor into memory.</li> <li>6. Zone is learned into wrong partition. Delete zone and learn into correct partition.</li> </ol>
Sensor reports trouble condition.	<ol style="list-style-type: none"> <li>1. Sensor tamper switch is tripped—sensor cover is off, not latched securely, or sensor is not mounted securely. Secure sensor mounting and/or cover, then trip sensor to clear the condition.</li> <li>2. Check the sensor battery for low voltage. Replace batteries, if necessary.</li> </ol>
Touchpad indicates <i>[sensor #] supervisory</i> and/or <i>Sensor [sensor #] supervisory</i> is heard.	<ol style="list-style-type: none"> <li>1. Use an RF Sniffer (60-401) to verify that sensor is transmitting. If sensor is not transmitting, check battery for low or no voltage and replace.</li> <li>2. Change mounting position of sensor (from horizontal to vertical or vice versa) and test sensor several times for consistency.</li> <li>3. Sensor signal is not reaching panel/receiver because sensor is too far away. Remove sensor from mounted location and test from other locations. Mount sensor in area where signal can reach panel/receiver.</li> </ol>
Smoke sensor beeps once every minute.	<ol style="list-style-type: none"> <li>1. Sensor batteries are getting low. Replace batteries.</li> </ol> <p><b>Note</b> Smoke sensors don't transmit a low battery signal to the panel/receiver until battery voltage drops to 2.5VDC. The described beep routine occurs earlier as a reminder to the customer to change batteries and avoid a central station/pager report.</p>

## Wireless Touchpads

---

**Table T14: Wireless Touchpad Troubleshooting**

Problem	Action/Solution
System doesn't respond to commands entered from wireless touchpad.	<ol style="list-style-type: none"> <li>1. Verify that receiver antennas are installed and connections are secure.</li> <li>2. Check that touchpad battery is installed.</li> <li>3. Check the touchpad battery for low voltage. Replace battery, if necessary.</li> <li>4. Use an RF Sniffer (60-401) to verify that touchpad is transmitting.</li> <li>5. Touchpad is not learned into panel memory. Enter program mode and learn touchpad into memory (see the <i>WIRELESS TOUCHPADS</i> menu in the "Programming" section).</li> <li>6. Touchpad is learned into wrong partition. Delete touchpad and learn into correct partition.</li> </ol>
Touchpad reports trouble condition.	<ol style="list-style-type: none"> <li>1. Check the touchpad battery for low voltage. Replace battery, if necessary.</li> </ol>

## Phones

---

**Table T15: Phone Troubleshooting**

Problem	Action/Solution
Loss of dial tone at on-site phones after wiring RJ-31X jack or connecting the DB-8 cord.	<ol style="list-style-type: none"> <li>1. Wait 2 minutes and try again. The panel may be busy trying to report to the central station.</li> <li>2. Disconnect the panel DB-8 cord from the RJ-31 jack. If the phone still doesn't work, the system is okay and the problem is in the wiring.</li> <li>2. Check RJ-31X jack wiring and TELCO block wiring. Replace RJ-31X jack if necessary.</li> <li>3. Check DB-8 cord connections at the panel and RJ-31X jack. Replace cord if necessary.</li> <li>4. Perform a phone test after troubleshooting the phone line.</li> </ol>
Constant dial tone, preventing dial-out on premises phones.	<ol style="list-style-type: none"> <li>1. One or more polarity-sensitive phones exist on-site. Reverse the phone wires connected to the brown and gray wire terminals on the RJ-31X jack.</li> </ol>

## Light Control

---

**Table T16: Light Control Troubleshooting**

Problem	Action/Solution
Light controlled by X-10 Lamp Module is not working.	<ol style="list-style-type: none"> <li>1. Check that the lamp has a working bulb and that the lamp switch is on.</li> <li>2. Check to make sure X-10 module is not plugged into an outlet controlled by a switch. Move to a nonswitched outlet location and test.</li> <li>3. Panel doesn't have a Power Line Carrier (PLC) card installed. Install PLC card.</li> <li>4. Panel is not powered by a power line carrier transformer. Replace existing transformer with a power line carrier transformer.</li> <li>5. Power transformer and X-10 modules are not plugged into outlets on the same electrical phase. Relocate modules or transformer to different outlets to determine working locations.</li> <li>6. Check that the HOUSE dial on the X-10 module matches the partition house code programmed into the panel.</li> <li>7. X-10 module is located in wrong partition. Move module to correct partition and retest.</li> <li>8. Partition house codes are not programmed into panel. Enter program mode and set partition house codes.</li> </ol>



# Appendix A: System Planning Worksheets

Fill in customer information about this installation.

Customer Name \_\_\_\_\_

Address \_\_\_\_\_

City \_\_\_\_\_ County \_\_\_\_\_ State \_\_\_\_\_

Zip \_\_\_\_\_ Phone (\_\_\_\_) \_\_\_\_\_

**Table A.1 Wireless Devices**

Part No.	Description	Qty.
60-362	Learn Mode Door/Window Sensor (Crystal)	
60-670	Learn Mode Door/Window Sensor (SAW)	
60-409	Learn Mode Recessed Door/Window Sensor	
60-499	Learn Mode Slim Line Door/Window Sensor	
60-688*	Learn Mode Micro Door/Window Sensor	
60-641	Learn Mode Long-Life Door/Window Sensor	
60-461*	Learn Mode Shock Sensor	
60-459*	Learn Mode Sound Sensor (ITI)	
60-462*	Learn Mode Glass Guard Sensor	
60-506	Learn Mode System Smoke Sensor	
60-460	Rate-of-Rise Heat Sensor	
60-589*	Manual Fire Pull Sensor	
60-504*	Learn Mode Freeze Sensor	
60-452	Learn Mode Pendant Panic Sensor	
60-458	Single Button Panic Sensor	
60-457	Dual Button Panic Sensor	
60-578	Water-Resistant Panic Sensor	
60-511	Learn Mode DS924i PIR Motion Sensor	
60-639-95R	SAW Indoor PIR Motion Sensor	
60-639-95R-OD	SAW Outdoor PIR Motion Sensor	
60-582	Learn Mode Sound Sensor (IntelliSense)	
60-645-95	Wireless Smoke Sensor (System Sensor 2300RFIT)	
60-597	HiTech Handheld Wireless Touchpad	
60-607	2-Button Keychain Touchpad	
60-606	4-Button Keychain Touchpad	

\* Not UL listed; not intended for use in UL listed systems.

**Table A.2 Hardwire Devices**

Part No.	Description	Qty.	mA	SubTot.
<b>Hardwire Sensors/Detectors</b>				
13-068*	Magnetic Contact 3/8" press fit		N/A	
13-070*	Magnetic Contact – surface mount		N/A	
13-360	ESL 449AT Smoke/Heat Detector		xx mA	
79-004*	Fire Pull Station		N/A	
13-028*	PIR Motion Detector		10 mA	
<b>Speakers/Sirens</b>				
60-736	Supervised Wireless Siren		N/A	
13-060	15-Watt, 8-Ohm Speaker		xx mA	
60-252	Hardwire Interior Speaker & Piezo		xx mA	
60-483-01	Slim Line Hardwire Interior Siren & Piezo		120 mA	
13-046	Hardwire Exterior Siren		145 mA	
<b>SuperBus/Miscellaneous Components</b>				
60-746	2x16 LCD Alphanumeric Touchpad		90 mA	
60-728	8Z LED Touchpad		65 mA	
60-777	Phone Interface/Voice Module		600 mA	
60-728	RF Receiver		30 mA	
60-584	Hardwire Input Module		18 mA	
60-585	Hardwire Output Module		91 mA	
60-620	SuperBus Energy Saver Module		10 mA	
60-677*	Interrogator 200 Audio Verification Module		10 mA	
			Total power consumption:	mA
			Total power consumption using 30 VA transformer and 4.0 AH backup battery not to exceed:	1,000 mA
			Total power consumption using 50 VA transformer and 7.0 AH backup battery not to exceed:	2,000 mA

**Table A.3 SuperBus Device Addresses**

SuperBus Device	Factory Default	Actual Setting
First Alphanumeric Touchpad	1	
Second Alpha. Touchpad	1	
Third Alpha. Touchpad	1	
Fourth Alpha. Touchpad	1	
First LED Touchpad	3	
Second LED Touchpad	3	
Phone Interface/Voice Module (Partition 1)	0	
Phone Interface/Voice Module (Partition 2)	0	
First RF Receiver	0	
Second RF Receiver	0	
Hardwire Input Module (HIM)	0	
Hardwire Output Module (HOM)	0	
Energy Saver Module (ESM)	0	

**Table A.4 Zone/Sensor Assignments**

No.	Group	Zone/Sensor Text
26		
27		
28		
29		
30		
31		
32		
33		
34		
35		
36		
37		
38		
39		
40		
41		
42		
43		
44		
45		
46		
47		
48		
49		
50		
51		
52		
53		
54		
55		
56		
57		
58		
59		
60		
61		
62		
63		
64		
65		
66		
67		
68		

**Table A.4 Zone/Sensor Assignments**

No.	Group	Zone/Sensor Text
01		
02		
03		
04		
05		
06		
07		
08		
09		
10		
11		
12		
13		
14		
15		
16		
17		
18		
19		
20		
21		
22		
23		
24		
25		

**Table A.4 Zone/Sensor Assignments**

No.	Group	Zone/Sensor Text
69		
70		
71		
72		
73		
74		
75		
76		

**Table A.5 Sensor Group Characteristics**

No.	Name	Application	Alarm	Delay	Restoral	Supervisory	CS Report	Chime	Active Levels
00	Fixed Panic	24-hour audible fixed emergency buttons.	Police	Instant		√	√		1, 2, 3
01	Portable Panic	24-hour audible portable emergency buttons.	Police	Instant			√		1, 2, 3
02	Fixed Panic	24-hour silent fixed emergency buttons.	Silent	Instant		√	√		1, 2, 3
03	Portable Panic	24-hour silent portable emergency buttons.	Silent	Instant			√		1, 2, 3
04	Fixed Auxiliary	24-hour auxiliary sensor, such as Pendant Panic or holdup button.	Auxiliary	Instant		√	√		1, 2, 3
05	Fixed Auxiliary	24-hour auxiliary emergency button. Siren shutoff confirms CS report.	Auxiliary	Instant		√	√		1, 2, 3
06	Portable Auxiliary	24-hour portable auxiliary alert button.	Auxiliary	Instant			√		1, 2, 3
07	Portable Auxiliary	24-hour portable auxiliary button. Siren shutoff confirms CS report.	Auxiliary	Instant			√		1, 2, 3
08	Special Intrusion	Special belongings, such as gun cabinets and wall safes.	Police	Instant	√	√	√		1, 2, 3
09	Special Intrusion	Special belongings, such as gun cabinets and wall safes.	Police	Standard	√	√	√		1, 2, 3
10	Entry/Exit Delay	Entry and exit doors that require a standard delay time.	Police	Standard	√	√	√	√	2, 3
11	Entry/Exit Delay	Garage doors and entrances that require an extended delay time. *	Police	Extended	√	√	√	√	2, 3
12	Entry/Exit Delay	Driveway gates and entrances that require a twice extended delay time. *	Police	Twice Extended	√	√	√	√	2, 3
13	Instant Perimeter	Exterior doors and windows.	Police	Instant	√	√	√	√	2, 3
14	Instant Interior	Interior doors.	Police	Follower	√	√	√		2, 3
15	Instant Interior	Interior PIR motion sensors. *	Police	Follower		√	√		2, 3
16	Instant Interior	Interior doors.	Police	Follower	√	√	√		3
17	Instant Interior	PIR motion sensors. *	Police	Follower		√	√		3

Table A.5 Sensor Group Characteristics (continued)

No.	Name	Application	Alarm	Delay	Restoral	Supervisory	CS Report	Chime	Active Levels
18	Instant Interior	PIR motion sensors subject to false alarms. * †	Police	Follower		√	√		3
19	Delayed Interior	Interior doors that initiate a delay before going into alarm. *	Police	Standard	√	√	√		3
20	Delayed Interior	PIR motion sensors that initiate a delay before going into alarm. *	Police	Standard		√	√		3
21	Local Instant Interior	24-hour local alarm zone protecting anything that opens and closes.	Police	Instant	√	√			1, 2, 3
22	Local Delayed Interior	Same as group 21, plus activation initiates a delay before going into alarm.	Police	Standard	√	√			1, 2, 3
23	Local Instant Auxiliary	24-hour local alarm zone protecting anything that opens and closes. ‡	Auxiliary	Instant	√	√			1, 2, 3
24	Local Instant Auxiliary	24-hour local alarm zone protecting anything that opens and closes. Sirens shut off at restoral. *	Auxiliary	Instant	√	√			1, 2, 3
25	Local Special Chime	Notify the user when a door is opened. Sounds emit from a local annunciator. *	Special Chime	Instant		√			1, 2, 3
26	Fire	24-hour fire, rate-of-rise heat, and smoke sensors. §	Fire	Instant	√	√	√		1, 2, 3
27	Output Module	Hardwire Output Module (HOM) lamp control or other customer feature. ‡	Silent	Instant	√	√			1, 2, 3
28	Output Module	HOM, PIR motion sensor, sound sensor, or pressure mat. ‡	Silent	Instant		√			1, 2, 3
29	Auxiliary	Freeze sensor.	Auxiliary	Instant	√		√		1, 2, 3
32	Output Module	HOM, PIR motion sensor, sound sensor, or pressure mat. ‡	Silent	Instant					1, 2, 3
33	Siren	Wireless Siren Supervision. ‡	Silent	Instant		√	√		1, 2, 3
34	Gas	Carbonmonoxide (CO) Gas Detectors ‡	Auxiliary	Instant	√	√	√		1, 2, 3

**Note:** Check marks (√) represent characteristics present in a group.

\* This group is not certified as a primary protection circuit for UL-listed systems and is for supplementary use only.

† Sounds instant police siren if two or more sensors are tripped within 4 minutes. Otherwise sensors are followers to delayed sensors. If Alarm Verification is on, group 18 functions like group 17.

‡ This group has not been investigated by UL.

§ This group is required for UL-listed residential fire alarm applications.



# Programming Mode Menus and Settings

To enter Programming Mode,  
8 + Installer or Dealer Code + 0 + 0

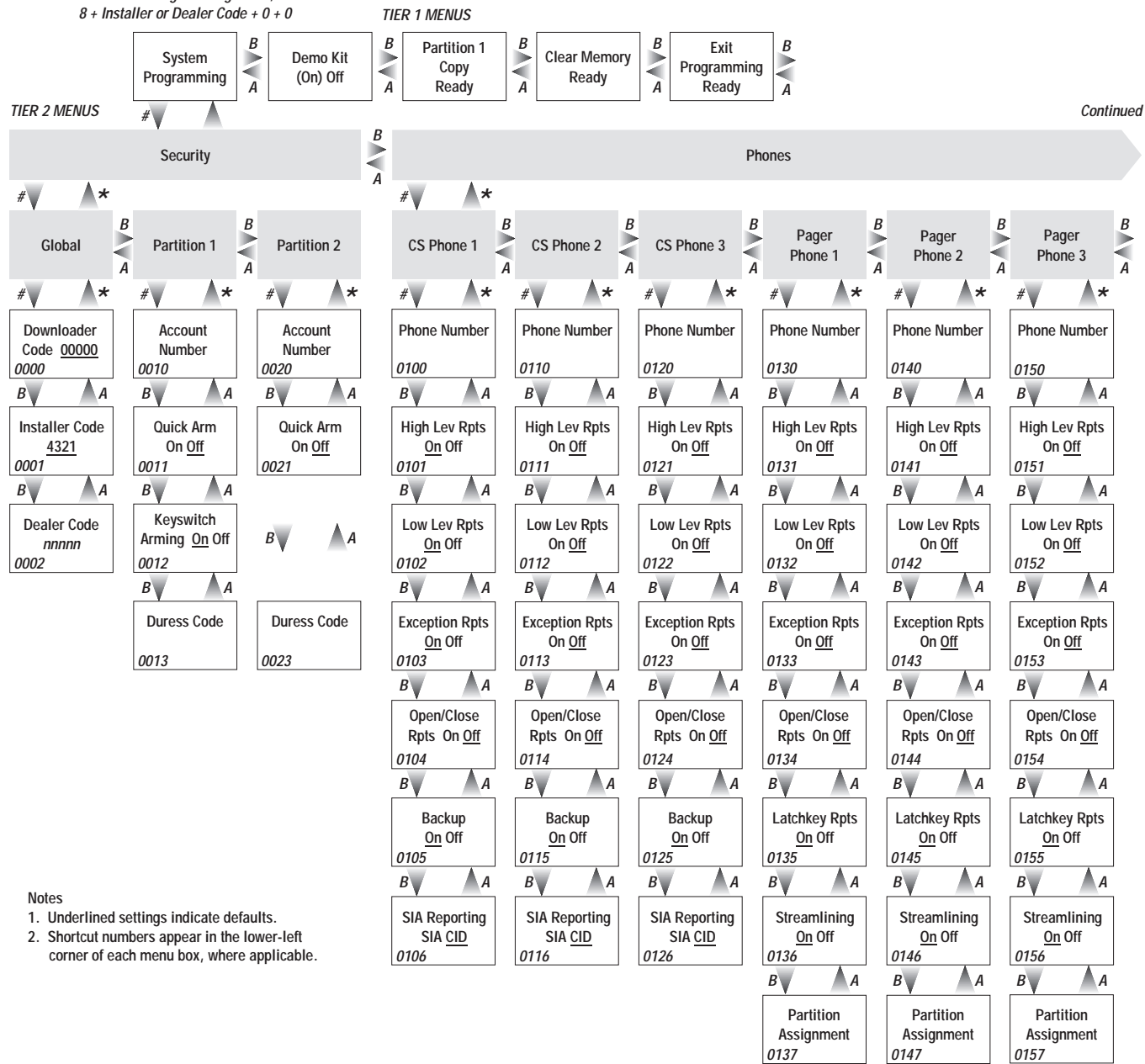

- Notes
- Underlined settings indicate defaults.
  - Shortcut numbers appear in the lower-left corner of each menu box, where applicable.

# Programming Mode Menus and Settings

Press B to continue to Light Control.

## TIER 2 MENUS

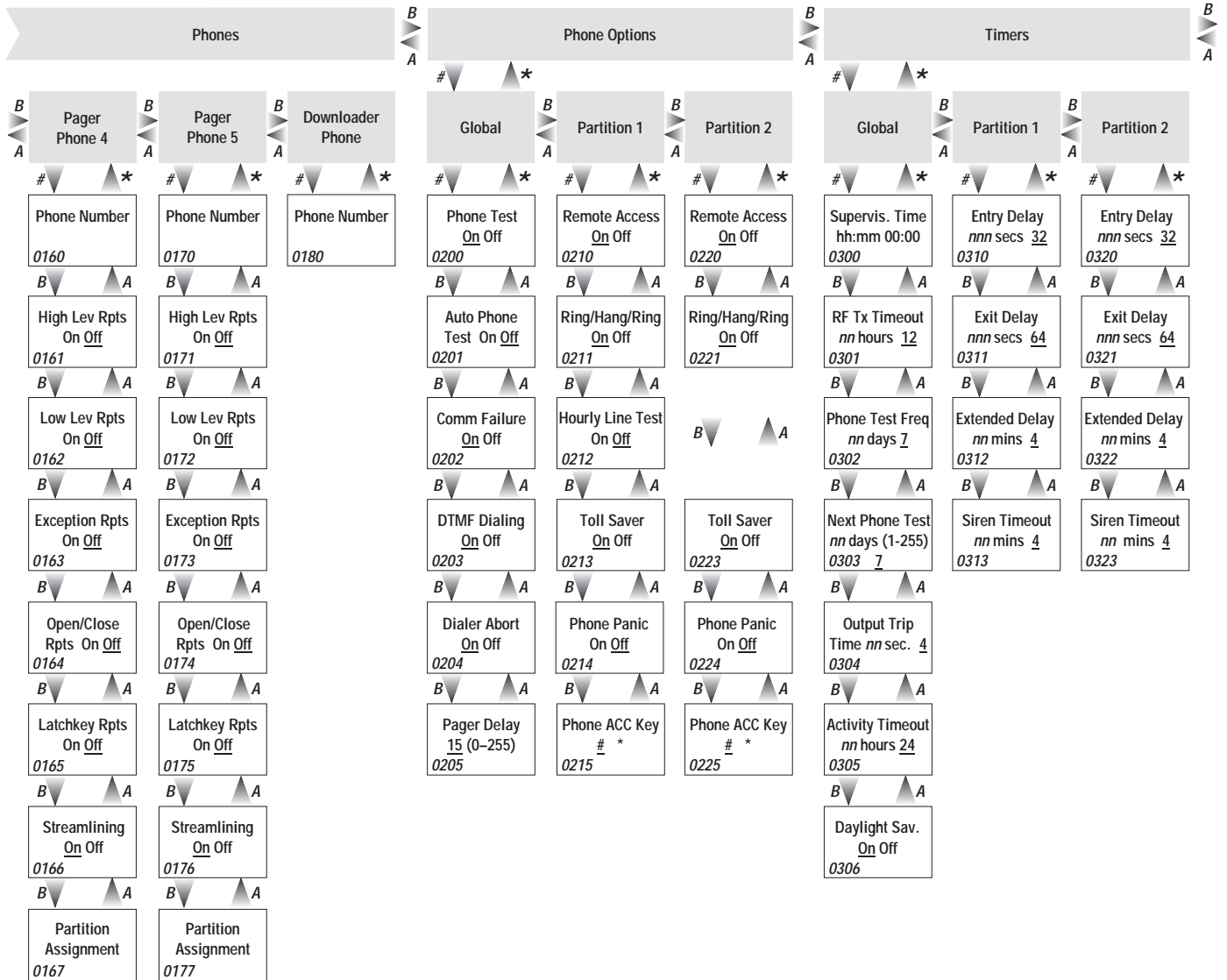

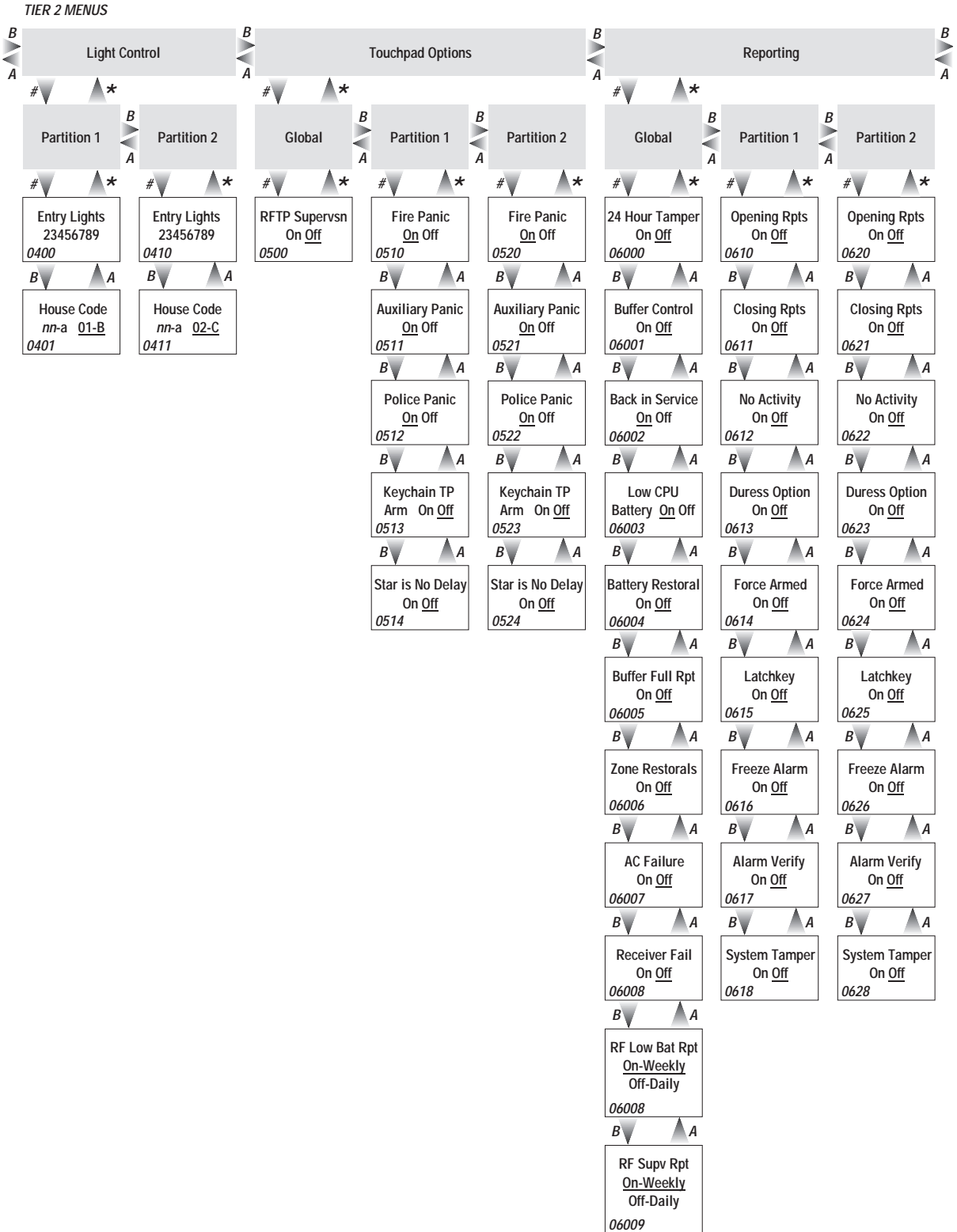

# Programming Mode Menus and Settings

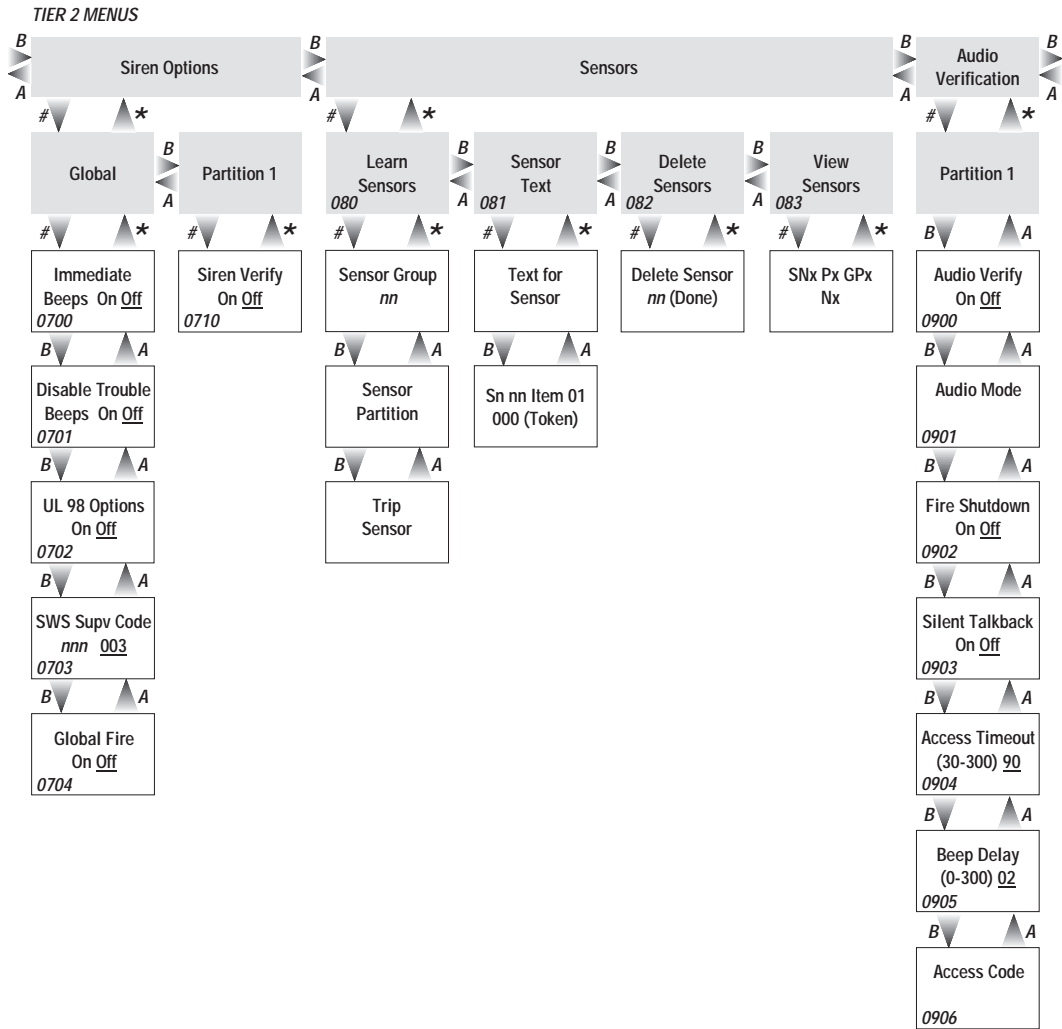

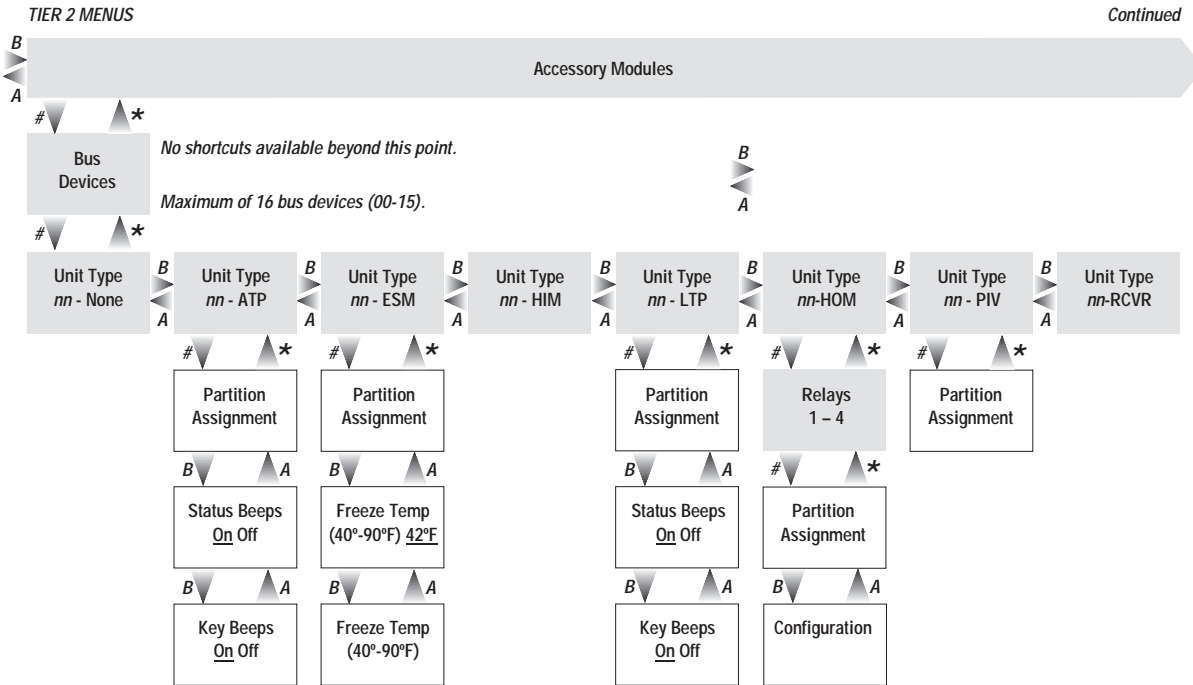

# Programming Mode Menus and Settings

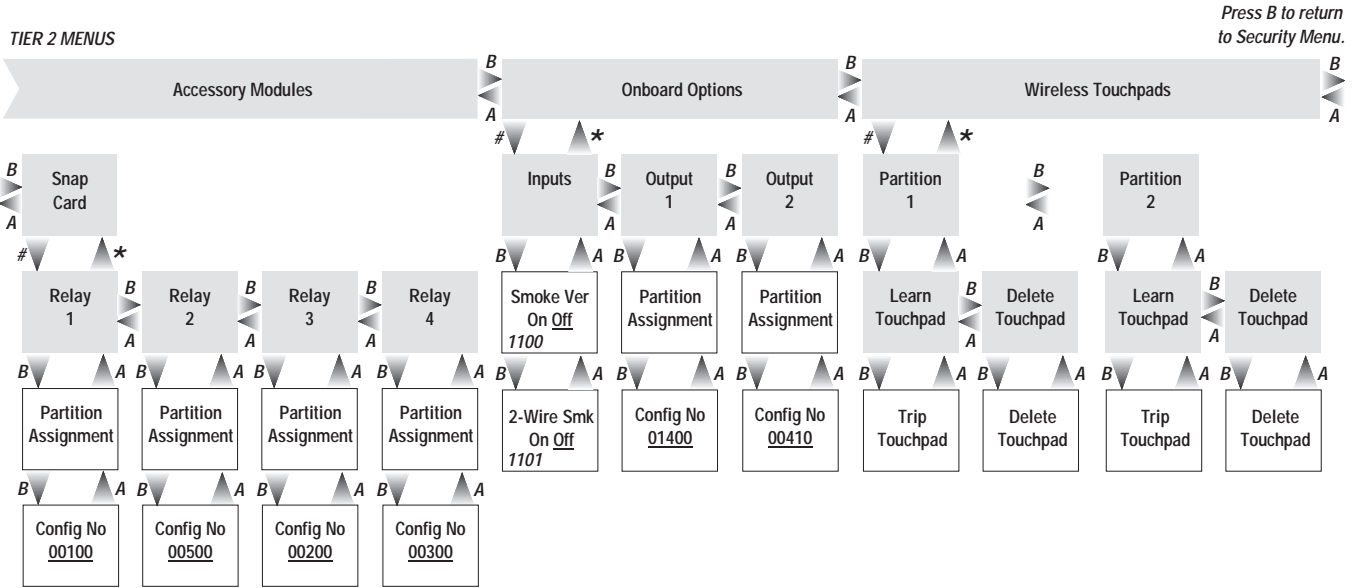



**Note 1**

Class II power transformer must be plugged into an unswitched AC power receptacle. Do not short the transformer terminals together. The transformer contains an internal fuse that permanently disables the output if the terminals are shorted.

**Note 2**

An alphanumeric touchpad is required for on-site programming. If the installation includes more than one touchpad, connect just one touchpad and use it to program system settings. When connecting additional touchpads, each one must be set with a unique (different) device address. Refer to the touchpad or panel installation instructions.

**Note 3**

Speaker terminals 7 and 8 activate only for alarms in partition 1. Use speakers with an 8-ohm or higher impedance. When connecting two or more 8-ohm speakers, they must be wired in series as shown in the wiring diagram. Wiring two or more 8-ohm speakers in parallel can permanently damage the panel.

**Note 4**

Onboard outputs 1 and 2 are open-collector type. Output 1 defaults to configuration number 01400. Output 2 defaults to configuration number 00410. Refer to panel installation instructions for all possible settings.

**Note 5**

Zone (loop) wiring shown is an example that applies to all zones (except when zone 8 is configured for 2-wire smoke detectors). Install EOL resistors across all unused zone (loop) inputs.

**Note 6**

For UL Listed installations, wire multiple supervised hardwire smoke detectors (10 maximum) only as shown. Maximum 10 uA current draw per detector. Maximum 80 mA current draw in alarm. Maximum 100 mA current draw in non-alarm state.

**Note 7**

Some telephones are polarity-sensitive. Green and red wires may need to be reversed.

**Note 8**

A maximum of two Audio Verification Modules are allowed. Wire multiple speakers in series, and power and microphone wires in parallel. Use shielded cable where shown in diagram to prevent cross-talk between the speaker and microphone. Audio Verification Modules shall not be used in UL Listed installations.

**Note 9**

Connect multiple piezo sirens in parallel. Status beeps do not sound from piezo sirens connected to outputs. Slim Line Hardwire Interior Siren status volume switch settings have no effect.

**Note 10**

All SuperBus devices be set with a different device address before applying power. Devices with the same device address setting will not work correctly. For installations with just one touchpad and one module, the default settings can be used.

**Note 11**

Refer to the Energy Saver Module installation instructions for thermostat wiring details.

**Note 12**

Wire Hardwire Input Module zone (loop) inputs as shown for the panel, except use 4.7k-ohm EOL resistors. Install EOL resistors across all unused zone (loop) inputs.



# System Wiring Notes